

VICINITY MAP

PROJECT LOCATION

TO HWY 62

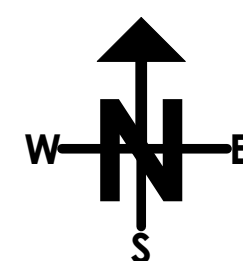

GOVERNING CODES:

Part 2, 2022 California Building Code (CBC), which is based on the 2021 International Building Code (IBC) published by the International Code Council (ICC).
 Part 2.5, 2022 California Residential Code (CRC), which is based on the 2021 International Residential Code (IRC) published by the International Code Council (ICC).
 Part 3, 2022 California Electrical Code (CEC), which is based on the 2017 & 20 National Electrical Code (NEC) published by the National Fire Protection Association (NFPA).
 Part 4, 2022 California Mechanical Code (CMC), which is based on the 2021 Uniform Mechanical Code (UMC) published by the International Association of Plumbing and Mechanical Officials (IAPMO).

Part 5, 2022 California Plumbing Code (CPC), which is based on the 2021 Uniform Plumbing Code (UPC) published by the International Association of Plumbing and Mechanical Officials (IAPMO).
 Part 6, 2022 California Energy Code (CEC), which is written by the California Energy Commission (CEC), and published by the California Building Standards Commission.
 Part 9, 2022 California Fire Code (CFC), which is based on the 2021 International Fire Code (IFC) published by the International Code Council (ICC).
 Part 11, 2022 California Green Building Standards Code (CGBCS), which is based on the 2021 International Building Code (IBC) published by the California Building Standards Commission.

COVER SHEET NOTES:

- 1.) Fire sprinklers are required per section R313 of the 2016 CRC
- 2.) project required a grading permit are required by Riverside County to provide a grading report after completion of rough grading. Structural engineer must be made aware of the finding within the final grading report. Engineer on record should fill out the "Foundation Design Verification Certificate" to certify that he/she has evaluated the findings within the approved Final Grading Report.
- 3.) Work shall be installed in accordance with the approved construction documents, and any changes made during construction that are not in compliance with the approved construction documents shall be resubmitted for approval as an amended set of construction documents. CRC R106.4.
- 4.) deferred submittal item:
Prior to installation, a minimum of two copies of truss calculations will be provided with the truss plan to be stamped and signed by the architect or civil/structural engineer licensed in the State of California. Likewise, every truss detail shall bear the signature of an architect or civil/structural engineer licensed in the State of California.
- 5.) deferred submittal items:
Truss layout shall be stamped and signed by an architect or civil/structural engineer licensed in the State of California.
- 6.) The Foundation Design Verification Certificate shall be completed and signed by the engineer of record.
- 7.) Photovoltaic Systems (deferred submittal)
The plan needs to show compliance with the 2019 CEC, 2019 CBC, and 2019 CRC. [§107.2 CBC] The plans shall be signed by the contractor who will perform the work. [§5536.1, 6735 California Business and Profession Code]
PV wiring, systems and interconnections shall only be installed by qualified persons. CEC 690.4(C) A-C10 or C46 license is required

PROJECT SCOPE

PROJECT DESIGN TEAM

RESIDENTIAL DESIGN BY:
JONATHAN PELEZZARE
 44550 Pierson Blvd. SPC 14, Desert Hot Springs, California 92240
 Phone: (760) 391-2748 Email: info@jonathanpelezzaredesign.com

STRUCTURAL ENGINEER
 RA STRUCTURAL ENGINEERING, INC.
 Steve Rastberger, P.E., Principal
 77579 Springfield Lane, Suite "D"
 Palm Desert, CA 92211
 PHONE: 760-360-9908
 FAX: 760-360-9903
 CELL: 760-360-9144

CIVIL ENGINEER
FOMOTOR ENGINEERING
 225 S. GARDEN DRIVE, SUITE 1-10
 PALM SPRINGS, CA 92262
 (951) 321-1842 Fax (951) 321-1742

GENERAL CONTRACTOR

ENERGY & HVAC
Scott Design and Title 24, Inc.
 74-818 Velie Way STE 8
 Palm Desert CA 92260
 (760) 702-5406
SD&T24INC

PLUMBING
EGLETT GUTIERREZ DESIGN
 1011 BERRY STREET
 PALM SPRINGS, CA 92266
 CELL: (760) 851-7934
 FAX: (760) 950-0020
 E-MAIL: eglettg@eglettg.com
 LIC # 13-44802

ELECTRICAL
RAYA
 ARCHITECTURAL LIGHTING & ELECTRICAL DESIGN

PROJECT INFORMATION

OWNER:

LEGAL DESCRIPTION

Zoning Occupancy group: RL
 Number of stories: Single
 Type of construction: Type V-B, Sprinklered
 Building OCC. Groups: Single Family

Area Calculations

TOTAL LOT AREA	=	
RESIDENCE COND. FLR. AREA		1,842.9 sq ft
2 CAR GARAGE FLR. AREA		465.8 sq ft
TOTAL BUILDING FOOT PRINT	=	2,308.7
COVERED PATIO AREAS		
		137.6 sq ft
		838.5 sq ft
TOTAL COVERED PATIOS	=	976.1 sq ft
LOT COVERAGE =		0.01 %

A custom (3 bedroom, 2^{1/2} bath) single family residence for:

YUCCA VALLEY, CA 92252

Builders set general notes:

1. THESE PLANS AND OR DESIGNS ARE PREPARED EXCLUSIVELY FOR: (SEE JOB TITLE ON THIS SHEET) AND ARE NOT TO BE GIVEN OR ASSIGNED TO ANY THIRD PARTY, OR REUSED ON ANOTHER SITE WITHOUT THE WRITTEN APPROVAL OF JONATHAN PELEZZARE.
2. ANY ERRORS OR DISCREPANCIES FOUND IN THESE PLANS ARE TO BE BROUGHT TO THE IMMEDIATE ATTENTION OF THE DESIGNER (JONATHAN PELEZZARE)
3. ALL SUB-CONTRACTORS SHALL FAMILIARIZE THEMSELVES WITH THESE PLANS AND THE SITE CONDITIONS PRIOR TO COMMENCING ANY WORK.
4. DIMENSIONS ARE FOR CONSTRUCTION PURPOSES. DO NOT SCALE DRAWINGS.
5. ALL WORK TO COMPLY WITH CITY AND OR COUNTY OF JURISDICTION REQUIREMENTS AND ORDINANCES.
6. AGENCY APPROVED PLANS SHALL BE KEPT AT THE JOB SITE AND SHALL NOT BE USED BY WORKMEN.
7. ALL DEBRIS SHALL BE REMOVED FROM PREMISES AND ALL AREAS SHALL BE LEFT IN A CLEAN CONDITION AT ALL TIMES. ALL DEMOLITION MATERIALS SHALL BE DISPOSED OF AS PER CITY RECYCLING REQUIREMENTS.
8. UNLESS OTHERWISE INDICATED, ALL WORK SHALL BE ACCOMPLISHED IN STRICT ACCORDANCE WITH MANUFACTURER'S OR SUPPLIER'S INSTRUCTIONS AND SPECIFICATIONS.
9. IT SHALL BE THE RESPONSIBILITY OF THE CONTRACTOR TO LOCATE AND PROTECT FROM DAMAGE ALL EXISTING AND NEW UTILITIES.
10. THE ELECTRICAL, STRUCTURAL AND STEEL SHOP DRAWINGS ARE SUPPLEMENTARY TO THE ARCHITECTURAL DRAWINGS. IT SHALL BE THE RESPONSIBILITY OF THE CONTRACTOR TO CHECK THE ARCHITECTURAL DRAWINGS PRIOR TO THE INSTALLATION OF ALL SUPPLEMENTARY WORK. UPON THE OCCURRENCE OF ANY DISCREPANCIES BETWEEN THE SUPPLEMENTAL DRAWINGS AND THE ARCHITECTURAL DRAWINGS THAT WOULD ENCUMBER OR CAUSE AN AWKWARD INSTALLATION, IT SHALL BE THE RESPONSIBILITY OF THE CONTRACTOR TO NOTIFY JONATHAN PELEZZARE AT ONCE FOR REVIEW AND CLARIFICATION. WORK SHALL COMMENCE UPON WRITTEN APPROVAL BY JONATHAN PELEZZARE.
11. WORK INSTALLED IN CONFLICT WITH THE ARCHITECTURAL DRAWINGS SHALL BE CORRECTED AT THE EXPENSE OF THE CONTRACTOR. REQUIRED CORRECTIVE WORK SHALL BE PERFORMED IN SUCH A MANNER THAT IT WILL NOT INTERFERE WITH OCCUPANCY OF THE PROJECT ON A TIMELY BASIS.
12. NO STRUCTURAL MEMBER SHALL BE SERIOUSLY WEAKENED OR IMPAIRED BY CUTTING, NOTCHING, OR OTHERWISE. ALL BEAMS, GUIDES, JOISTS, STUDS AND SIMILAR CONSTRUCTION SHALL BE BORED WITH HOLES APPROXIMATELY THE SAME DIAMETER AS THE PIPES PASSING THROUGH THEM.
13. UNLESS THE DESIGNER IS RETAINED TO PROVIDE ON SITE REPORTS DURING CONSTRUCTION THE OWNER AND/OR HIS CONTRACTOR ASSUME COMPLETE RESPONSIBILITY FOR THE PROPER USE AND EXECUTION OF THE PLANS. ANY CHANGES OR DEVIATIONS FROM THESE PLANS WITHOUT THE WRITTEN CONSENT OF JONATHAN PELEZZARE RELEASES JONATHAN PELEZZARE FROM ANY LIABILITY FOR THE ENTIRE PROJECT.
14. THIS SET OF PLANS, PER THE CONTRACT WITH JONATHAN PELEZZARE, IS A BUILDER'S SET OF PLANS. THIS MEANS THAT NOT ALL DETAILS AND SPECIFICATIONS ARE PROVIDED AND THE GENERAL AND SUB-CONTRACTORS WILL BE REQUIRED TO HAVE GENERAL CONSTRUCTION KNOWLEDGE AND MAY REQUIRE SHOP OR INSTALLATION DRAWINGS FOR MANUFACTURED OR OTHER SPECIAL ITEMS TO COMPLETE THE STRUCTURE.
15. IT SHALL BE THE RESPONSIBILITY OF THE CONTRACTOR TO REVIEW ALL DRAWINGS AND SPECIFICATIONS PRIOR TO SUBMITTING BIDS FOR THIS PROJECT. SHOULD THE CONTRACTOR REQUIRE CLARIFICATION OF ANY DETAIL, ASSEMBLY, SPECIFICATION, DESIGN INTENT, ETC., SUCH CLARIFICATION SHALL BE REQUESTED PRIOR TO THE SUBMITTAL OF ANY BIDS. FURTHER, THE CONTRACTOR SHALL HOLD ALL SUB-CONTRACTORS RESPONSIBLE FOR REQUESTING SUCH CLARIFICATION OF ANY PORTION OF THE WORK PERTAINING TO THEIR BIDS.
16. THIS SET OF PLANS SHALL BE USED ONLY IN CONJUNCTION WITH THE SPECIFICATIONS INCLUDED HEREIN AND OR THE MANUFACTURER'S SPECIFICATIONS & INSTRUCTIONS (SEE NOTE 8 ABOVE) & ALL DOCUMENTATION PERTAINING TO THE CIVIL, STRUCTURAL, ELECTRICAL, & MECHANICAL (INCLUDING TITLE 24 SPECIFICATIONS) & ANY OTHER ENGINEERS WORK. ALL DRAWINGS, DETAILS, SPECIFICATIONS, & DOCUMENTATION SHALL CONSTITUTE THE COMPLETE SET OF PLANS. ALL "WORKING RENDERINGS" INCLUDED WITHIN THIS SET OF DOCUMENTS (ALL SHEETS LISTED IN INDEX OF DRAWINGS ON THIS SHEET) WITH RESPECT TO THE ACTUAL BUILDING STRUCTURE, FINISHES AND PERMANENTLY INSTALLED EQUIPMENT, APPLIANCES & CABINETS ARE PROVIDED TO INDICATE THE DESIGN INTENT AND ARE TO BE CONSIDERED AS EQUAL IN IMPORTANCE TO THE PLANS AND DETAILS PROVIDED HEREIN.
17. ALL ITEMS INDICATED ON PLANS AS "CUSTOM" SHALL REQUIRE SHOP DRAWINGS TO BE SUBMITTED BY THE CONTRACTOR OR SUB-CONTRACTOR RESPONSIBLE FOR PROVIDING & INSTALLING THE WORK. JOB ORDER THE DESIGNER JONATHAN PELEZZARE FOR APPROVAL PRIOR TO ORDERING MATERIALS, FABRICATION & INSTALLATION OF THE WORK ITEM.
18. THE ROOFING CONTRACTOR SHALL BE RESPONSIBLE FOR PROVIDING & INSTALLING ALL ROOFING MATERIAL (MENTIONED HEREIN OR NOT) & LABOR REQUIRED FOR A COMPLETE & FINISHED ROOF INSTALLATION MEETING OR EXCEEDING ROOFING INDUSTRY STANDARDS OF CARE & QUALITY & READY FOR FINAL OCCUPANCY INSPECTION & CERTIFICATION. INCLUDING ANY PREPARATIONS REQUIRED TO PREPARE THE ROUGH FRAMING FOR THE INSTALLATION OF ANY UNDER-LAYMENT OR BASE MATERIAL SUCH AS SLIP & OR FELT BASE SHEETS TO BE PROVIDED, SHEET METAL FLASHING & COUNTER FLASHING, SOLDERED SEAM SHEET METAL ROOFING, CLAY ROOF TILES, MEMBRANE ROOFING, SEALANTS, FASTENERS & ALL OTHER COMPONENTS REQUIRED FOR A COMPLETE ROOF INSTALLATION.

Project Title Sheet Renderings



Index of Drawings

SHEET #	SHEET CONTENTS
A1.0	TITLE SHEET: VICINITY MAP, MUNICIPAL CODE, DESIGN TEAM, PROJECT INFORMATION, INDEX OF DRAWINGS
A1.1	2022 CALIF. GREEN BUILD. STANDARDS CODE RESIDENTIAL MANDATORY MEASURES 1
A1.2	2022 CALIF. GREEN BUILD. STANDARDS CODE RESIDENTIAL MANDATORY MEASURES 2
A1.3	MANUFACTURERS REPORTS & SPECIAL SYSTEMS
A1.4	PRECISE GRADING & DRAINAGE PLAN TITLE SHEET
A1.5	PRECISE GRADING & DRAINAGE PLAN
A1.6	Erosion Control
A2.1	NOT USED
A3.00	SITE FLOOR PLAN (1/8" = 1'-0")
A3.01	
A3.1	
A3.2	
A3.3	
A3.4	
A3.5	
A4.00	FLOOR PLAN (DIMENSIONED)
A4.01	FLOOR PLAN (KEYED NOTES)
A4.02	FLOOR PLAN (SECTION CUTS)
A4.03	FLOOR PLAN - DOOR & WINDOW SCHEDULES
A4.5	ROOF PLAN
A4.6	LOW ROOF LAYOUT & DUCT ROUTING
A4.7	NOT USED
A5.0	EXTERIOR ELEVATIONS
A6.1	NOT USED
A6.0	BUILDING SECTIONS A THRU D
A6.1	BUILDING SECTIONS E THRU I
A6.2	BUILDING SECTIONS J THRU M
A6.3	BUILDING SECTIONS N THRU S
A6.4	
A6.5	NOT USED
A9.0	ARCHITECTURAL DETAILS
M1.0	HVAC LAYOUT
M2.0	HVAC NOTES & DETAILS
M3.0	HVAC TITLE 24
M3.1	HVAC TITLE 24
E1.0	ELECTRICAL PLAN & SYMBOLS
E2.0	ELECTRICAL NOTES
E3.0	ELECTRICAL PANEL, LOAD CALCS, SINGLE LINE & PANEL SCHEDULE
P1.0	PLUMBING NOTES & DETAILS
P1.1	PLUMBING FLOOR PLAN
P2.0	PLUMBING ISOMETRICS
GN	GENERAL NOTES
SIT	Special Inspection Table
GD	GENERAL DETAILS & NOTES
S-1	Foundatin Plan
S-2	Low Roof Framing Plan
S-3	High Roof Framing Plan
SD-1	Foundation Details
SD-1A	Foundation Details
SD-2	Framing Details
SD-3	Framing Details
HFX-1	Hardy Frame Foundation Details
HFX-2	Hardy Frame Framing Details
TJ1	TJ1 Installation Details

WEBSITE / PROMOTIONAL DOCUMENT DISTRIBUTION:

THESE DRAWINGS, DETAILS, ELECTRONIC FILES, AND PORTIONS OF PLAN SETS MAY BE DELETED, DISTRIBUTED, OR MADE AVAILABLE THROUGH THE WEBSITE OF RESIDENTIAL DESIGN BY: JONATHAN PELEZZARE FOR PROMOTIONAL, EDUCATIONAL, HISTORICAL, OR REFERENCE PURPOSES ONLY. NO LICENSE IS GRANTED FOR THE CONSTRUCTION, REPRODUCTION, MODIFICATION, REUSE, SALE, PREPARATION OF DERIVATIVE WORKS, OR REPLICATION OF THESE DESIGNS, DRAWINGS, DETAILS, OR ELECTRONIC FILES WITHOUT THE EXPRESS WRITTEN CONSENT OF RESIDENTIAL DESIGN BY: JONATHAN PELEZZARE. ANY UNAUTHORIZED USE, CONSTRUCTION, COPYING, MODIFICATION, DISTRIBUTION, OR RELIANCE UPON THESE DOCUMENTS OR ELECTRONIC FILES SHALL BE AT THE SOLE RISK OF THE USER. RESIDENTIAL DESIGN BY: JONATHAN PELEZZARE ASSUMES NO RESPONSIBILITY OR LIABILITY FOR ANY DAMAGES, LOSSES, CLAIMS, DEFECTS, CODE VIOLATIONS, CONSTRUCTION ERRORS, OR OTHER CONSEQUENCES ARISING FROM THE UNAUTHORIZED USE OR MISUSE OF THESE DOCUMENTS OR ELECTRONIC FILES.

© COPYRIGHT 2024 - RESIDENTIAL DESIGN BY: JONATHAN PELEZZARE - ALL RIGHTS RESERVED

RESIDENTIAL DESIGN BY:
JONATHAN PELEZZARE
 44550 Pierson Blvd. SPC 14
 Desert Hot Springs, California 92240
 Phone: (760) 391-2748 Email: info@jonathanpelezzaredesign.com

TITLE SHEET: VICINITY MAP, MUNICIPAL CODE, DESIGN TEAM, PROJECT INFORMATION, INDEX OF DRAWINGS

A custom residence for:
Yucca Valley, CA

DRAWN:
 CHECKED:
 DATE: 5/30/2024
 SCALE:
 JOB #:
 SHEET NO:

A1.0
 OF 41 SHEETS

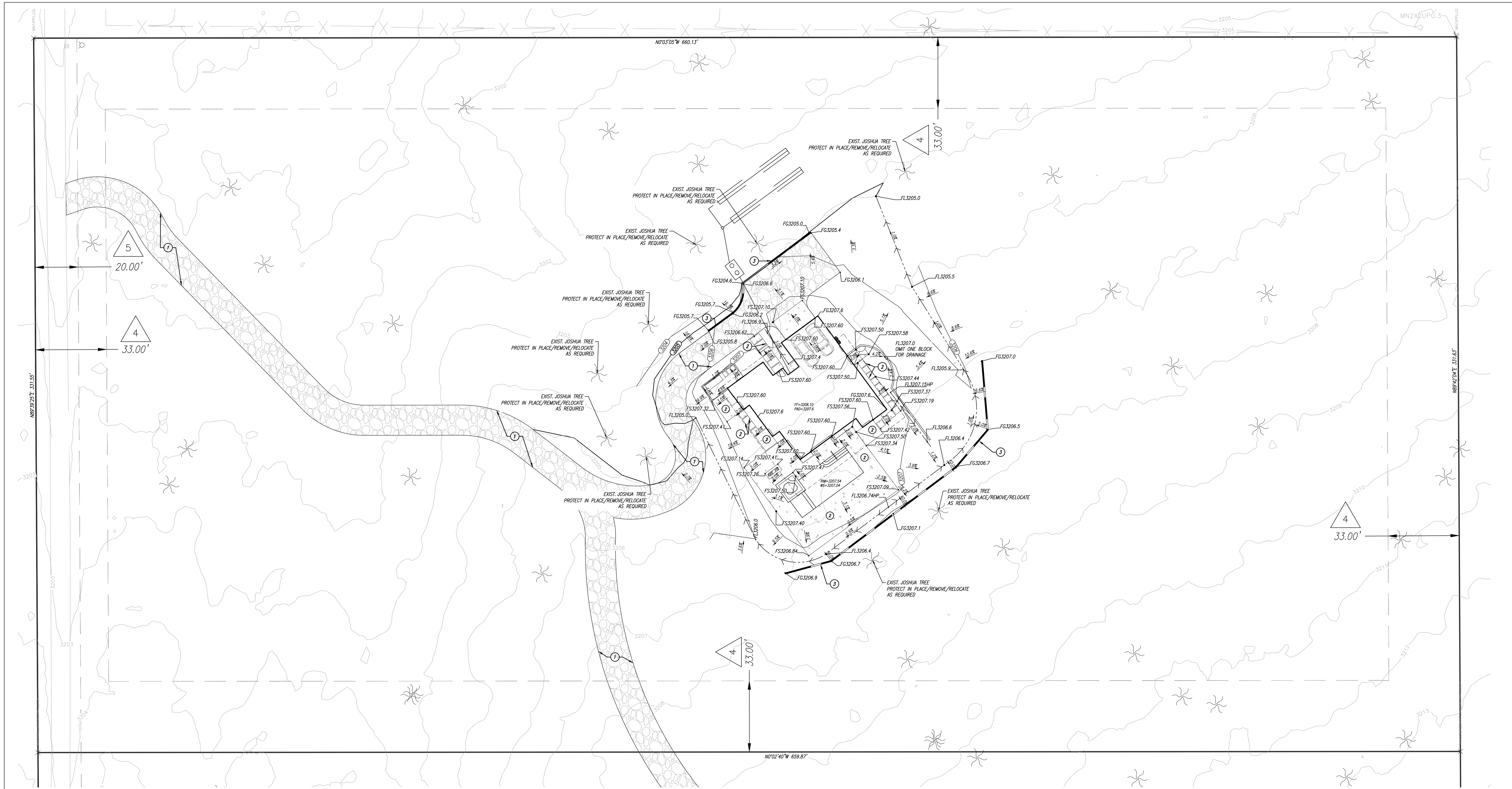

CONSTRUCTION NOTES

- ① CONSTRUCT 15' WIDE DRIVEWAY WITH COMPACTED BASE
- ② CONSTRUCT 4" THICK SIDEWALK AND WALKWAYS PER COUNTY OF SAN BERNARDINO STD DWG 109
- ③ CONSTRUCT RETAINING WALL PER SEPARATE PERMIT (2' MAX HEIGHT)
- ④ CONSTRUCT SCREEN WALL PER SEPARATE PERMIT

EASEMENT NOTES

- ④ RESERVATIONS AND EXCEPTIONS IN THE PATENT BY THE UNITED STATES RECORDED NOVEMBER 09, 1967 IN BOOK 6921 PAGE 515 OF OFFICIAL RECORDS.
- ⑤ AN EASEMENT FOR PIPE LINE FOR WATER PURPOSES, WITH THE RIGHT OF INGRESS AND EGRESS AND RIGHTS INCIDENTAL, IN FAVOR OF HI-DESERT WATER DISTRICT, RECORDED AUGUST 06, 1973 IN BOOK 8240 PAGE 692 O.R.

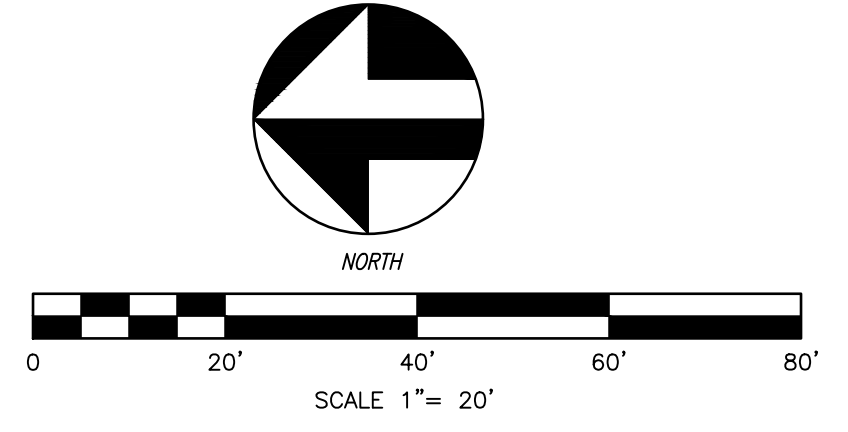

DIG ALERT
 BIAL BEFORE YOU DIG
 TOLL FREE 1-800-287-2600
 A PUBLIC SERVICE BY UNDERGROUND SERVICE ALERT

BENCHMARK
 ELEVATION: 2538.80' NAVD88
 DESCRIPTION: NGS PID EV3989
 TRIANGULATION STATION DISK STAMPED
 "GIANT 1965" SET IN CONCRETE.
 LOCATION: 2.07 MILES WEST ON POLE LINE
 ROAD FROM INTERSECTION OF POLE LINE
 ROAD AND LEAR THEN ALONG THE EAST
 SIDE OF 67622 POLE LINE ROAD 300FT
 NORTH TO STATION ON LEFT.

"RECORD DRAWING"		CORRECTED BY	APPROVED BY
NO.	REVISION	DATE	DATE
DESIGNED BY:	DRAWN BY:	CHECKED BY:	

**COUNTY OF SAN BERNARDINO
 DEPARTMENT OF LAND USE SERVICES**
 SFR# 2021-00327
 GRAD# 2020-00160

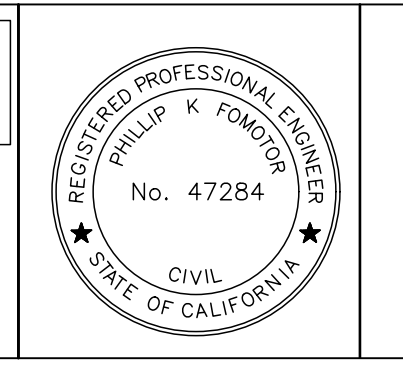

PREPARED UNDER THE DIRECT SUPERVISION OF:
FOMOTOR ENGINEERING
 FOR REVIEW PURPOSES ONLY DATE: _____
 PHILLIP K. FOMOTOR PE, PLS.
 R.C.E. NO. 47284

225 S. CIVIC DRIVE, SUITE 1-5
 PALM SPRINGS, CA. 92262
 (760) 323-1842 FAX (760) 323-1742

COUNTY OF SAN BERNARDINO, STATE OF CALIFORNIA		PREPARATION DATE: 31 August 2022
PRECISE GRADING PLAN	FILE NO.	SHEET 2
FOR	DWG NO.	OF 3 SHEETS

(NOTE: PROVIDED HERE FOR CONVENIENCE - VERIFY ALL INFORMATION WITH ACTUAL PRECISE GRADING PERMIT SET)

COUNTY OF SAN BERNARDINO, STATE OF CALIFORNIA
EROSION CONTROL PLAN
 FOR

LOT 45 SECTION 4, TOWNSHIP 1 NORTH, RANGE 6 EAST SAN
 BERNARDINO BASE AND MERIDIAN

ADDITIONS TO GENERAL NOTES FOR GRADING/EROSION CONTROL PLANS

Any slopes with disturbed soils or denuded of vegetation must be stabilized so as to inhibit erosion by wind and water.

Sediments and other materials may not be tracked from the site by vehicle traffic. The construction entrance roadways must be stabilized so as to inhibit sediments from being deposited into the public way. Accidental depositions must be swept up immediately and may not be washed down by rain or other means.

Construction sites shall be maintained by implementation of Best Management Practices (BMPs) in such a manner that pollutants are not discharged from the site to the maximum extent practicable.

Flooded sediments and other pollutants must be retained on site and may not be transported from the site via sheetflow, swales, area drains, natural drainage or wind.

Stockpiles of earth and other construction related materials must be protected from being transported from the site by the forces of wind and water.

Fuels, oils, solvents and other toxic materials must be stored in accordance with their listing and are not to contaminate the soil and surface waters. All approved storage containers are to be protected from the weather. Spills must be cleaned up immediately and disposed in a proper manner. Spills may not be washed into the drainage system.

Excess or waste concrete may not be washed into the public right-of-way or any other drainage system. Provisions shall be made to retain concrete wastes on site until they can be disposed of as solid waste.

All non-stormwater discharges, unless exempt or authorized by an NPDES permit require prior approval by the State Water Resources Control Board.

Trash and construction-related solid wastes must be deposited into a covered receptacle to prevent contamination of rainwater and dispersal by wind.

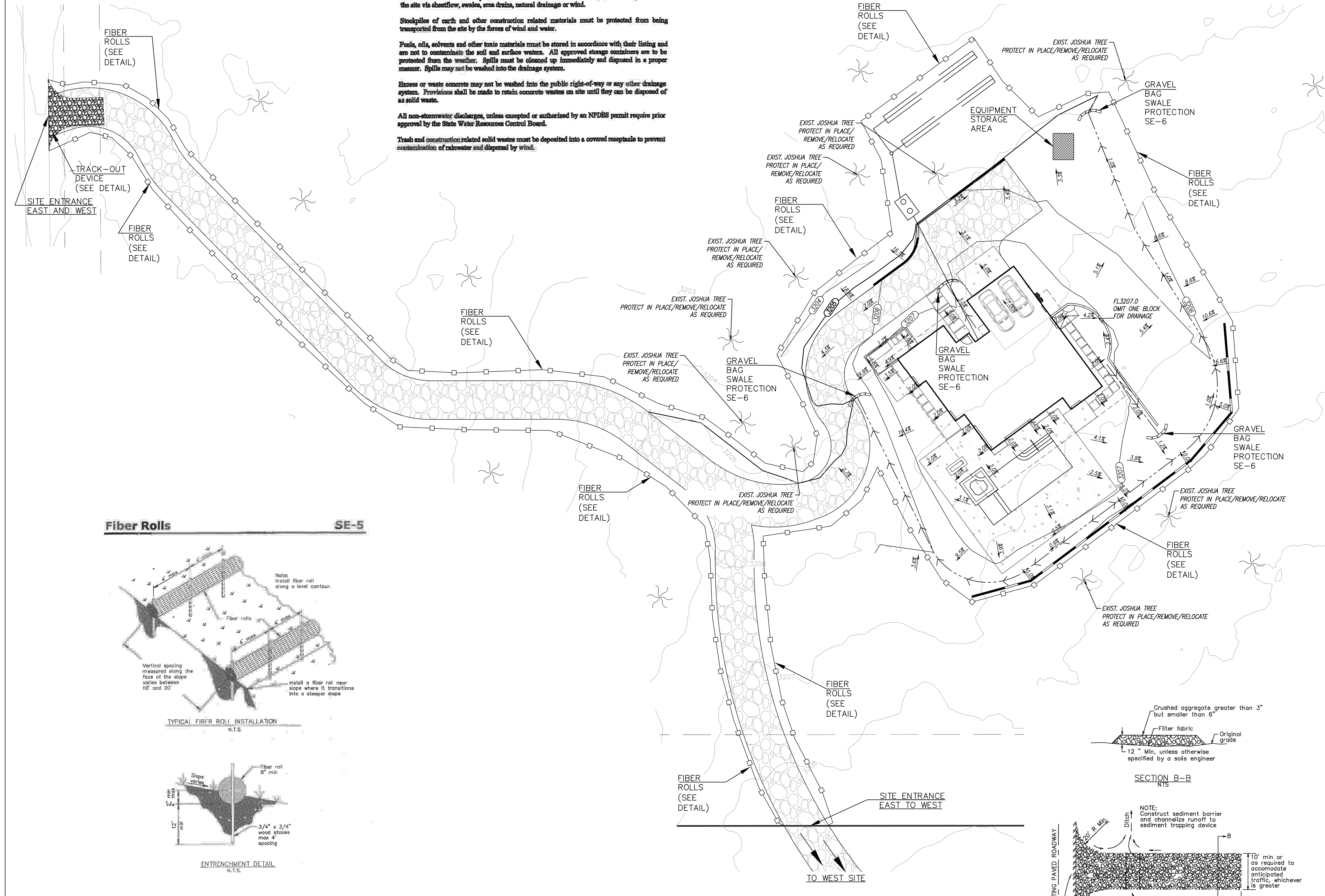

Erosion Control Notes:

- In case of emergency, call **Merdad Haidari** at **760-391-2748**
- Pollution and erosion prevention measures, also known as Best Management Practices (BMPs), must be installed prior to grading. These measures, including the prevention of sedimentation or flood damage, to offsite property shall be adequate whether or not an erosion control permit is required.
- Eroded sediments and other pollutants must be retained onsite and may not be transported from the site via sheet flow, swales, area drains, natural drainage courses, or wind.
- Erosion Control devices shall be functioning at all times. In case of failure, rapid construction of emergency devices shall be implemented.
- Stockpiles of earth and other construction-related materials must be protected from being transported from the site by the forces of wind or water.
- Fuels, oils, solvents, and other toxic materials must be stored in accordance with their listing and are not to contaminate the soils and surface waters. All approved storage containers are to be protected from the weather. Spills must be cleaned up immediately and disposed of in a proper manner. Spills may not be washed into the drainage system.
- Excess or waste concrete must be contained onsite. Provisions shall be made to retain concrete wastes onsite until they can be disposed of as solid waste.
- Developers/contractors are responsible to ensure all Erosion Control Devices and BMPs are installed and functioning properly per plan. Proper precaution shall be considered when 50% or greater probability of predicted precipitation, and after actual precipitation. A construction site inspection checklist and inspection log shall be maintained at the project site at all times and available for review by the Building Official.
- Trash and construction-related solid wastes must be deposited into a covered receptacle to prevent contamination of rainwater and dispersal by wind.
- Sediments and other materials may not be tracked from the site by vehicle traffic. The construction entrance roadways must be stabilized so as to inhibit sediments from being deposited into the public way. Accidental depositions must be swept up immediately and may not be washed down by rain or other means.
- Any slopes with disturbed soils or denuded of vegetation must be stabilized so as to inhibit erosion by wind and water.
- All silt and debris shall be removed from all devices within 24 hours after each rainstorm and be disposed of properly.
- All storm water capture devices shall be protected at all times.

Fiber Rolls SE-5

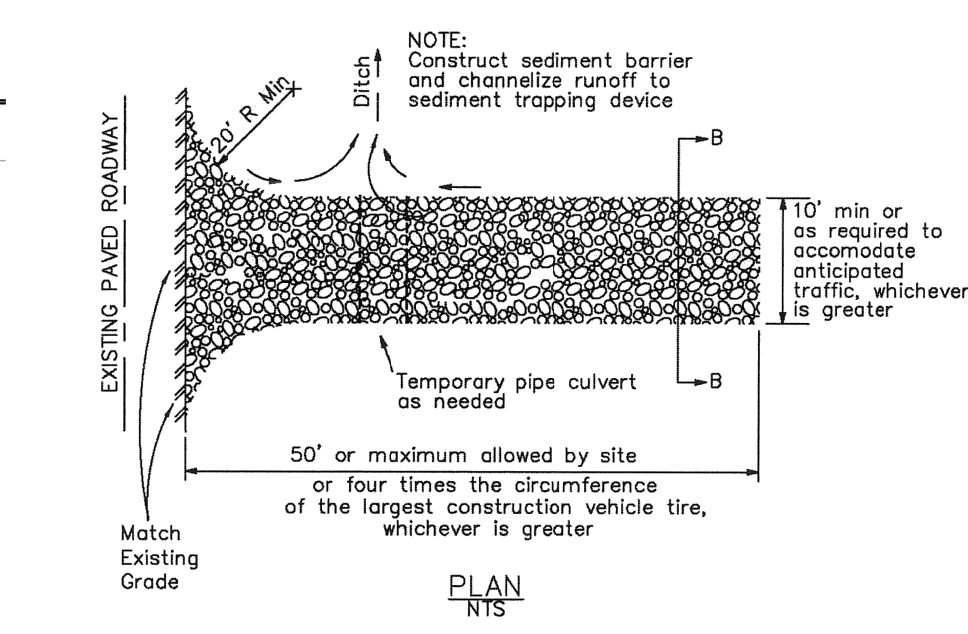
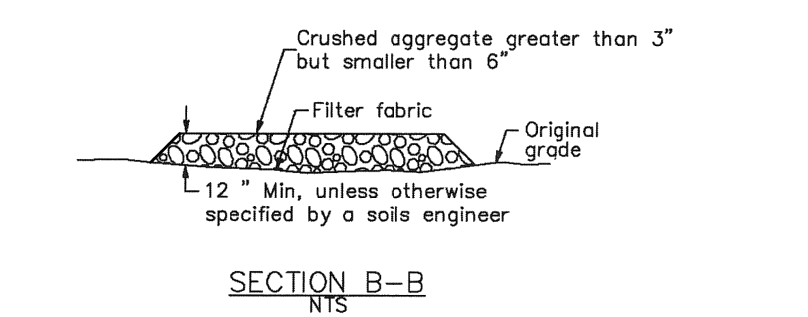
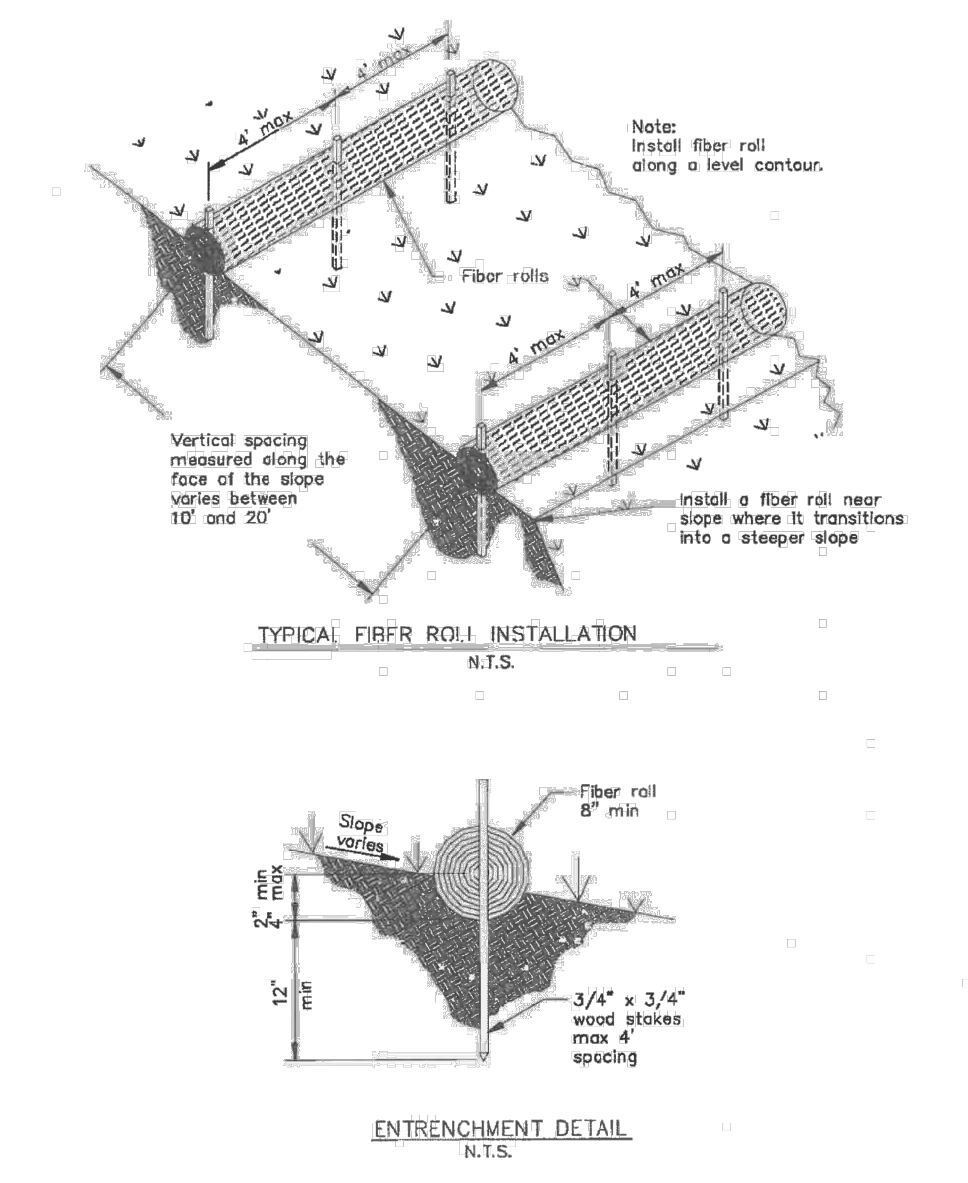

LEGEND

- PROP. SWALE
- EX. CONTOUR
- PROP. CONTOUR
- PROPOSED FIBER ROLLS
- GRAVEL BAG BARRIER (AS PER SWPPP BMP SE-6 AND 10)
- PROPOSED MATERIAL STORAGE AREA

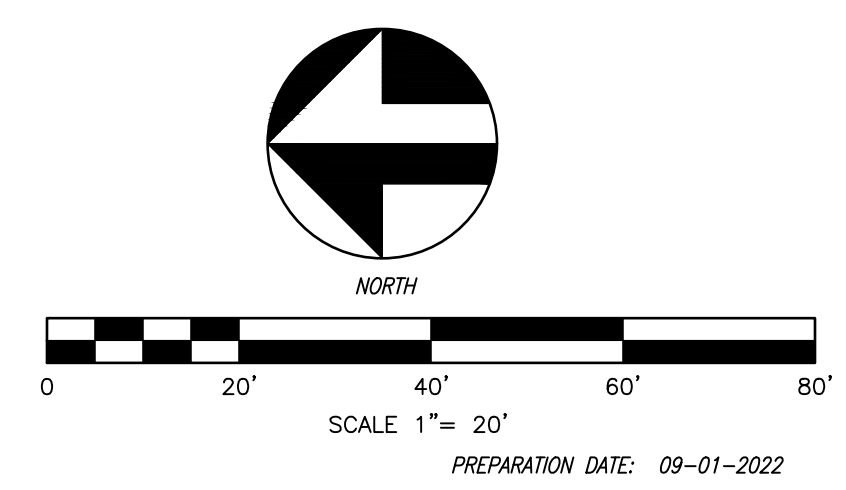

DIGALERT
 BIAL BEFORE YOU DIG
 TOLL FREE 1-800-227-2600
 A PUBLIC SERVICE BY UNDERGROUND SERVICE ALERT

BENCHMARK
 ELEVATION: 2538.80' NAVD88
 DESCRIPTION: NGS PID: EV3989
 TRIANGULATION STATION DISK STAMPED
 "GIANT 1965" SET IN CONCRETE.
 LOCATION: 2.07 MILES WEST ON POLE LINE ROAD FROM INTERSECTION OF POLE LINE ROAD AND LEAR THEN ALONG THE EAST SIDE OF 67622 POLE LINE ROAD 300FT NORTH TO STATION ON LEFT.

REVISION		NO.	DATE

COUNTY OF SAN BERNARDINO
DEPARTMENT OF LAND USE SERVICES
 SFR# 2021-00327
 GRAD# 2020-00160

REGISTERED PROFESSIONAL ENGINEER
 PHILLIP K. FOMOTOR
 No. 47284
 CIVIL
 STATE OF CALIFORNIA

PREPARED UNDER THE DIRECT SUPERVISION OF:
FOMOTOR ENGINEERING
 225 S. CIVIC DRIVE, SUITE 1-5
 PALM SPRINGS, CA 92262
 (760) 323-1842 FAX (760) 323-1742

COUNTY OF SAN BERNARDINO, STATE OF CALIFORNIA	FILE NO.	SHEET 1
EROSION CONTROL PLAN		OF
FOR	DWG NO.	1 SHEETS

(NOTE: PROVIDED HERE FOR CONVENIENCE - VERIFY ALL INFORMATION WITH ACTUAL PRECISE GRADING PERMIT SET)

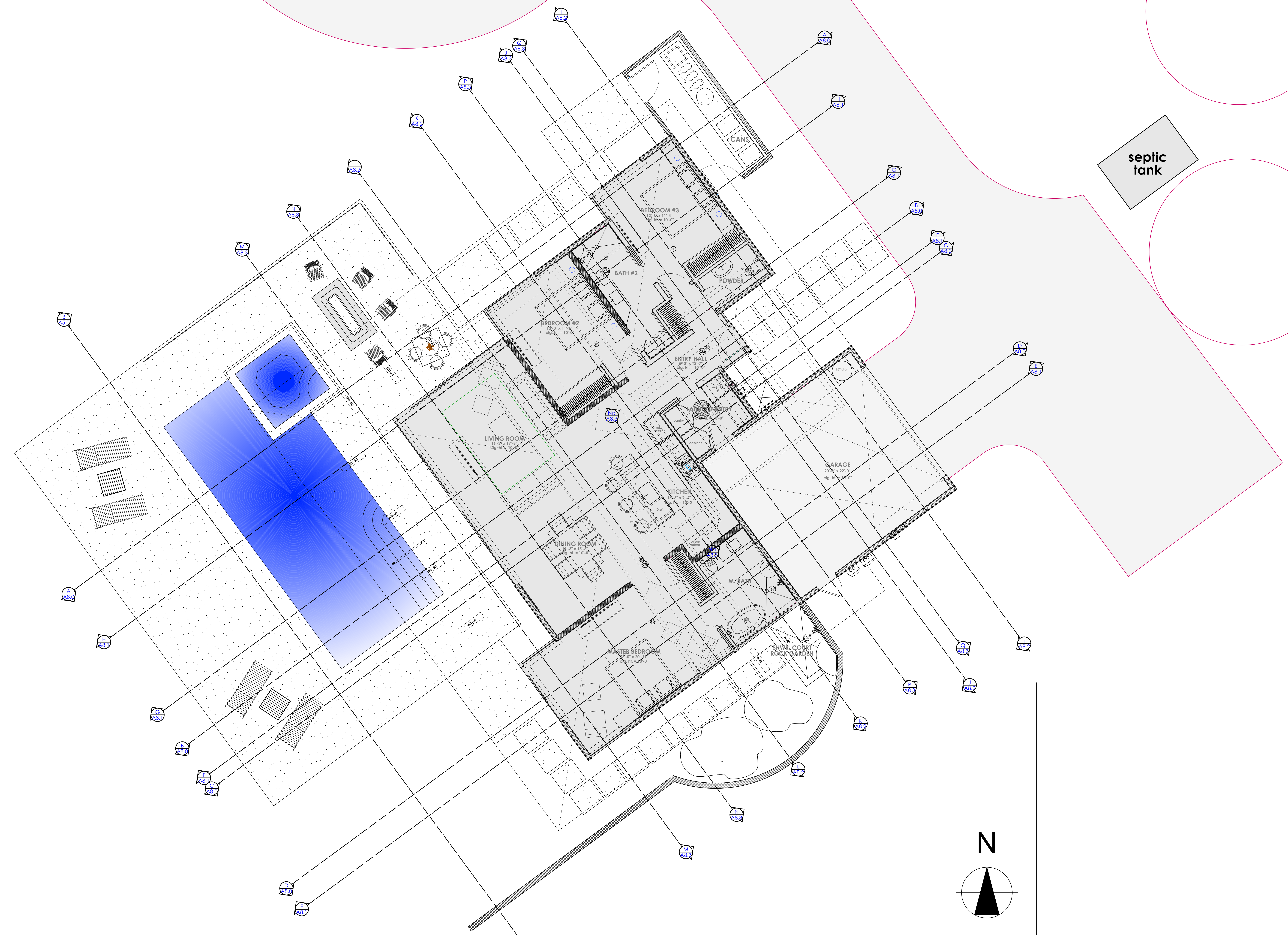

septic tank

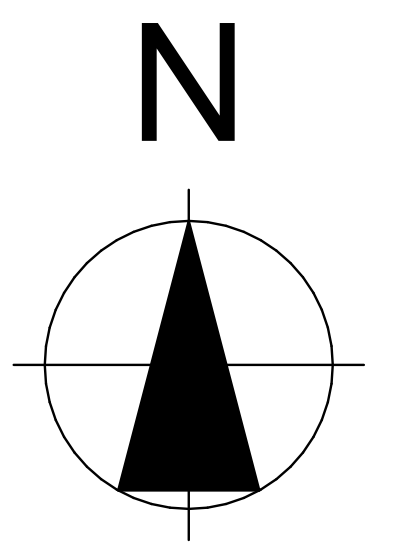

8' 4' 2' 0

SCALE: 1/4" = 1'-0"

FLOOR PLAN (SECTION CUTS)

RESIDENTIAL DESIGN BY:
JONATHAN PELEZZARE
 4459 Yucca Valley Blvd, SFC 14
 Yucca Valley, CA 92086
 Phone: (760) 371-2748 Email: jonathan@jonathandesign.com

FLOOR PLAN (SECTION CUTS)

A custom residence for:
 Yucca Valley, CA

DATE:	5/30/2024
CHECKED:	
SCALE:	1/4" = 1'-0" (UNIFORM)
JOB #:	
TR:	
SHEET NO.:	A4.02
TOTAL SHEETS:	09 OF 10 SHEETS

ROOF PLAN KEYED NOTES & DETAILS

3-1/2" J-WEEP HIGH-BACK PLASTER STOP					
Product	Quantity	Unit	Material	Finish	Package
JWP	10	EA	3/4" x 1/2" x 3/4"	White	10
JWP	100	EA	3/4" x 1/2" x 3/4"	White	100

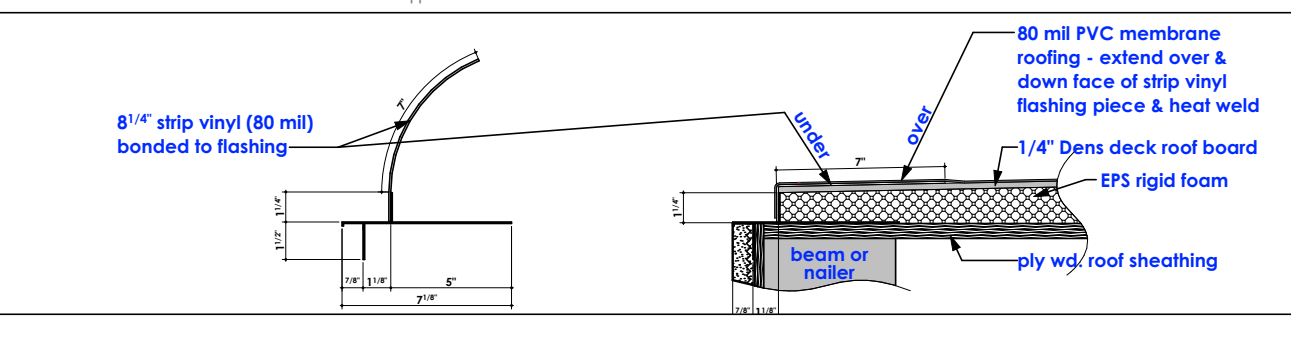

(Class A roof assembly)
 80 mil PVC membrane roofing ("COOL ROOF")
 over 1/4" dens deck roof board over EPS rigid foam
 package tapered to achieve 1/4" per ft. slope as
 indicated on plan.
 Note: install EPS tapered foam roof package
 to provide a minimum thickness of 1 1/2" over all living
 spaces (= min. R value of 6.9 above the roof deck)

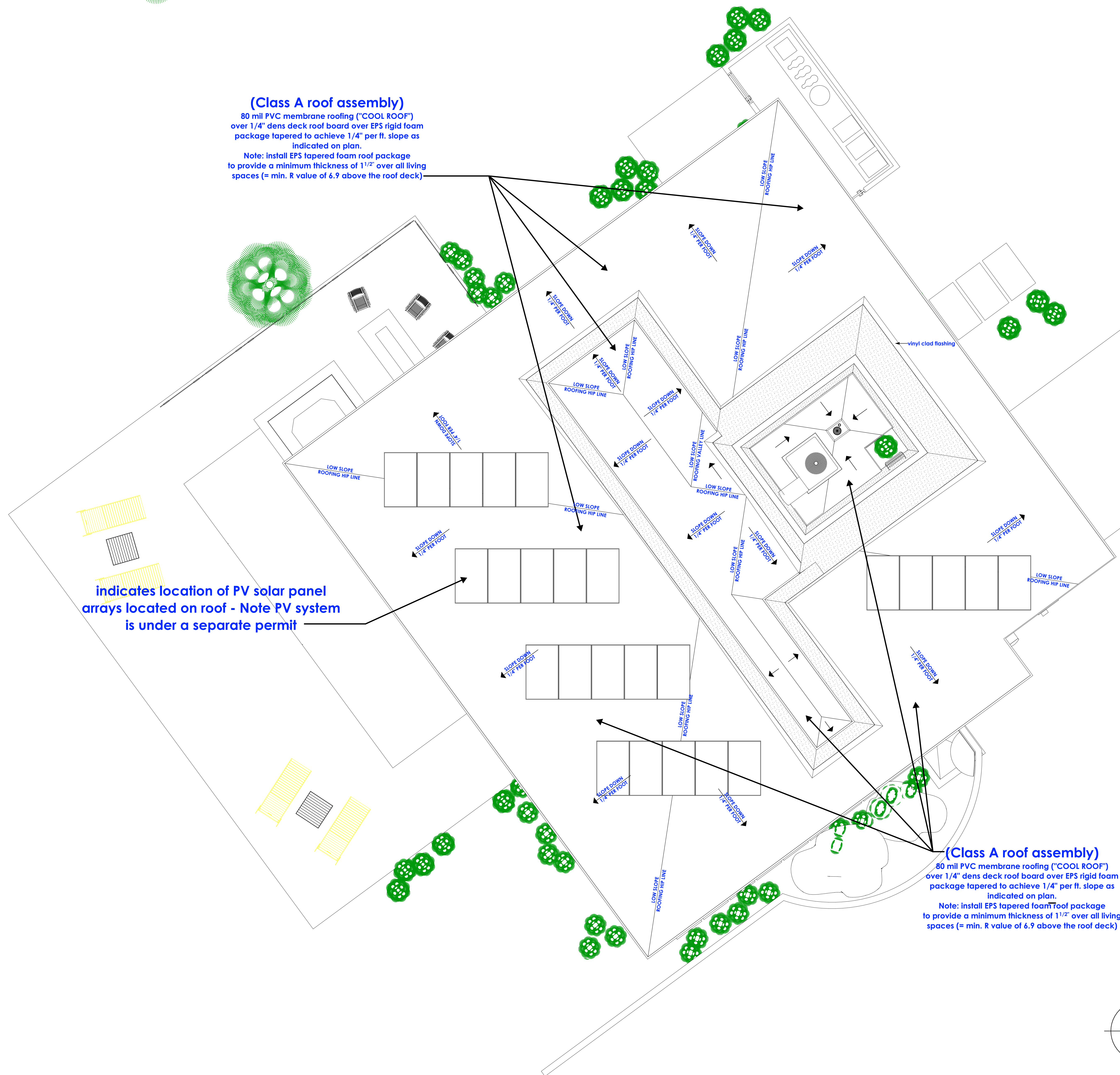

(Class A roof assembly)
 80 mil PVC membrane roofing ("COOL ROOF")
 over 1/4" dens deck roof board over EPS rigid foam
 package tapered to achieve 1/4" per ft. slope as
 indicated on plan.
 Note: install EPS tapered foam roof package
 to provide a minimum thickness of 1 1/2" over all living
 spaces (= min. R value of 6.9 above the roof deck)

- New roofing shall be class A rated minimum, R-19.
- Roof ICC Report
SEE SHEET A1.3 FOR REPORTS
- Unit skylights shall be tested by an approved independent laboratory, and bear a label identifying manufacturer, performance grade rating and approved inspection agency to indicate compliance with the requirements of aama/wdmn/csa 101/1.S.2/A440.
- Where roof drains are required, overflow drains having the same size as the roof drains shall be installed with the inlet flow line located 2 inches (51mm) above the low point of the roof. (R903.4.1)
- Gas vents must extend above the roof a minimum 1ft. (figure 8-2, CMC 802.6)
- Roofs on which equipment is to be installed shall be capable of supporting the additional load.
- All wood sleepers at the roof to be pressure treated, flashed, and protected by the roof membrane. Alternately, replace with plastic, trex, or standoff support.
- Enclosed rafter spaces do not require venting if the following specific insulation design is used, per Section R806.5/EM3.9.6:
 - If the insulation is air-permeable and it is installed directly below the roof sheathing with rigid board or sheet insulation with a minimum R-4 value installed above the roof sheathing.
 - (or)
 - If the insulation is air-impermeable and it is in direct contact with the underside of the roof sheathing.
 - (or)
 - If two layers of insulation are installed below the roof sheathing: An air-impermeable layer in direct contact with the underside of the roof sheathing and an additional layer of air permeable insulation installed directly under the air-impermeable insulation.

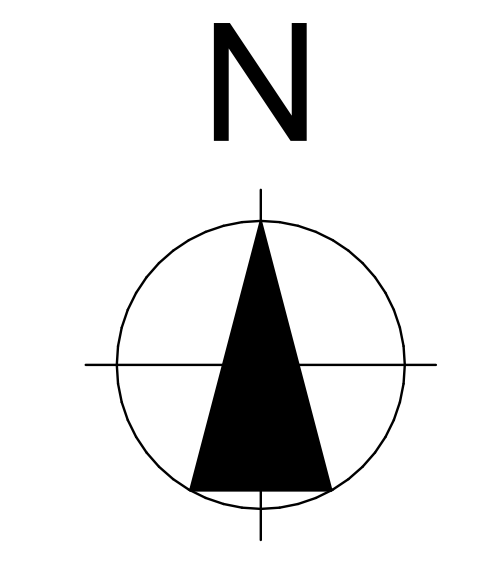

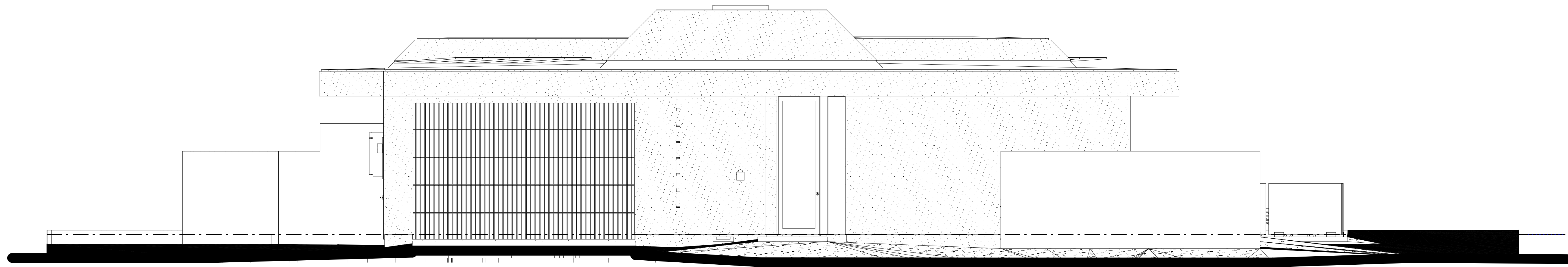

FRONT - (NORTHEAST) EXTERIOR ELEVATION

SCALE: 1/4" = 1'-0"

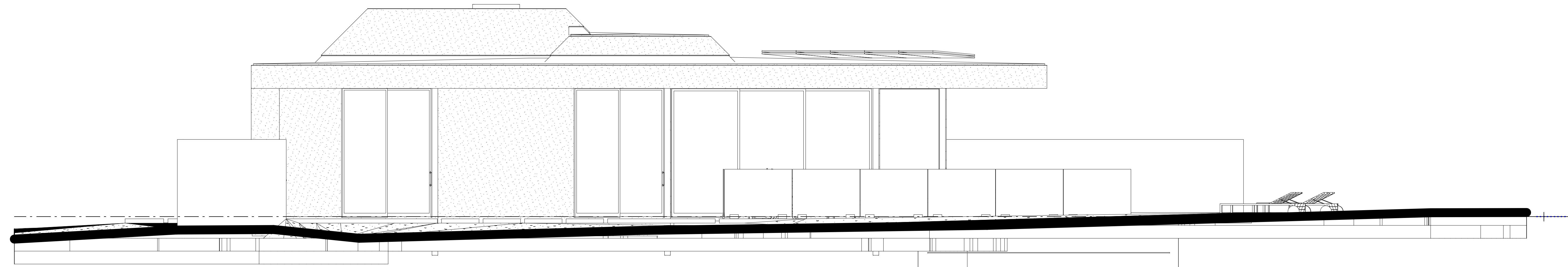

RIGHT SIDE (NORTHWEST) EXTERIOR ELEVATION

SCALE: 1/4" = 1'-0"

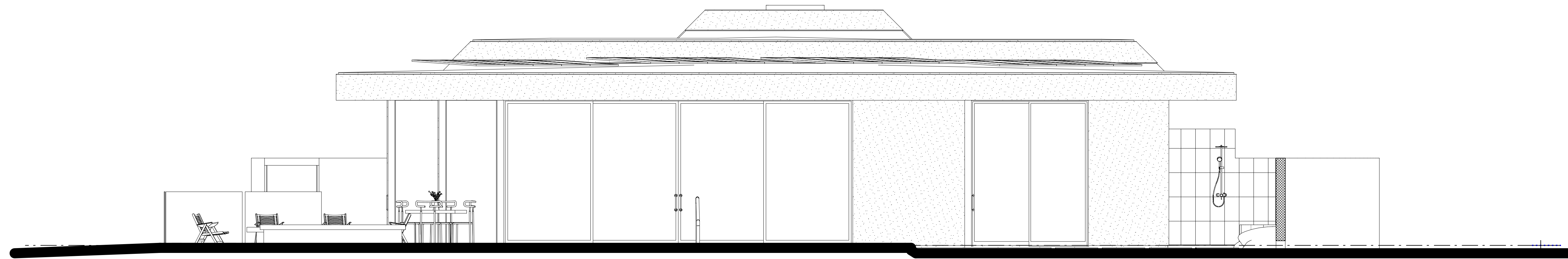

REAR - (SOUTHWEST) EXTERIOR ELEVATION

SCALE: 1/4" = 1'-0"

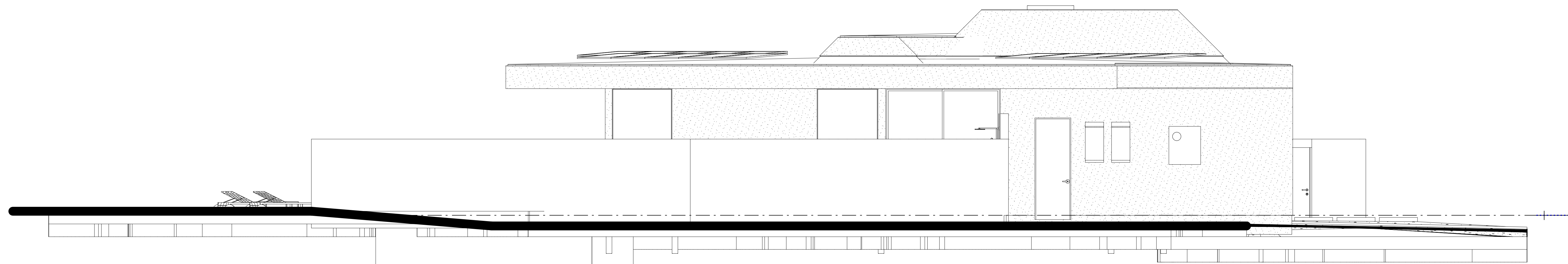

LEFT SIDE - (SOUTHEAST) EXTERIOR ELEVATION

SCALE: 1/4" = 1'-0"

REVISIONS
RESIDENTIAL DESIGN BY:
JONATHAN PELEZZARE
4459 Persimmon Blvd, SPC 14
Yucca Valley, CA 92084
Phone: (760) 371-2748
Email: info@jonathandesign.com

EXTERIOR ELEVATIONS

A custom residence for:
Yucca Valley, CA

DRAWN:
CHECKED:
DATE: 5/30/2026
SCALE: 1/2" = 1'-0"
JOB #:
SHEET NO.:
A5.0
OF 43 SHEETS

SPECIAL INSULATION NOTES:

All roof joist cavity spaces over living areas are "UN-VENTED" and are to receive minimum 2" thickness of "Energysield CGF PRO" insulation board (@ R-6 per inch thickness) placed against (in contact with) the underside of the ply wd. roof sheathing w/ typical R-38 fiberglass bat insulation directly under and against (in contact with) the CGF insulation board as indicated on the first building section of each sheet (total insulation value = R-50).
 — Indicates Energysield CGF PRO insulation board — Indicates R-38 fiberglass batt insulation

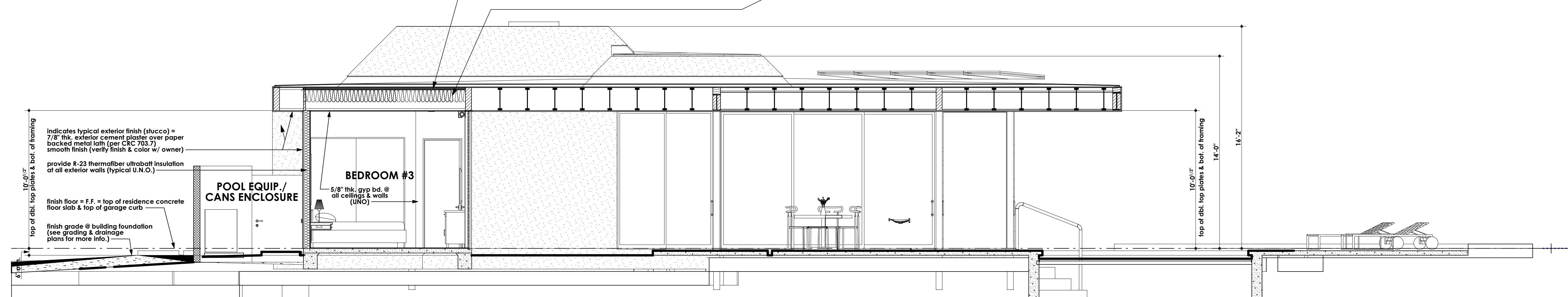

BUILDING SECTION A/A8.0

SCALE: 1/4" = 1'-0"

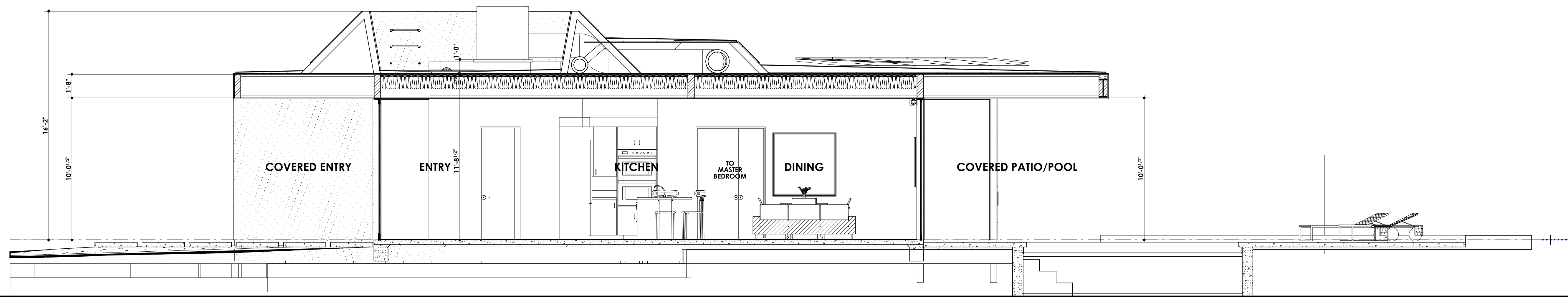

BUILDING SECTION B/A8.0

SCALE: 1/4" = 1'-0"

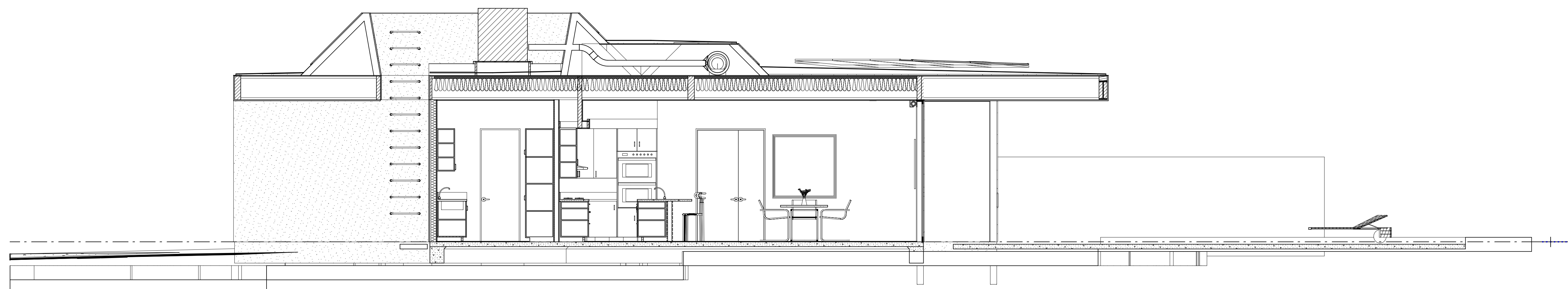

BUILDING SECTION C/A8.0

SCALE: 1/4" = 1'-0"



BUILDING SECTION D/A8.0

SCALE: 1/4" = 1'-0"

REVISIONS
 RESIDENTIAL DESIGN BY:
JONATHAN PELEZZARE
 4459 Pericon Blvd, Suite 114
 Yucca Valley, CA 92086
 Phone: (760) 371-2748
 Email: info@jonathandesign.com

BUILDING SECTIONS A THRU D

A custom residence for:
 Yucca Valley, CA

DRAWN:
 CHECKED:
 DATE: 5/30/2024
 SCALE: 1/4" = 1'-0" (UNO)
 JOB #:
 SHEET NO.:
A8.0
 OF 43 SHEETS

SPECIAL INSULATION NOTES:

All roof joist cavity spaces over living areas are "UN-VENTED" and are to receive minimum 2" thickness of "Energysield CGF PRO" insulation board (@ R-6 per inch thickness) placed against (in contact with) the underside of the ply wd. roof sheathing w/ typical R-38 fiberglass bat insulation directly under and against (in contact with) the CGF insulation board as indicated on the first building section of each sheet (total insulation value = R-50). Indicates Energysield CGF PRO insulation board. Indicates R-38 fiberglass batt insulation.

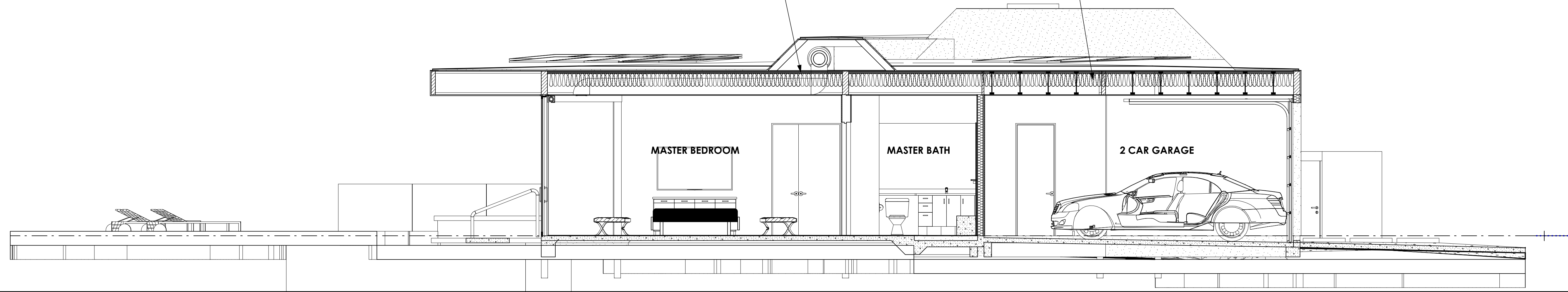

BUILDING SECTION E/A8.1

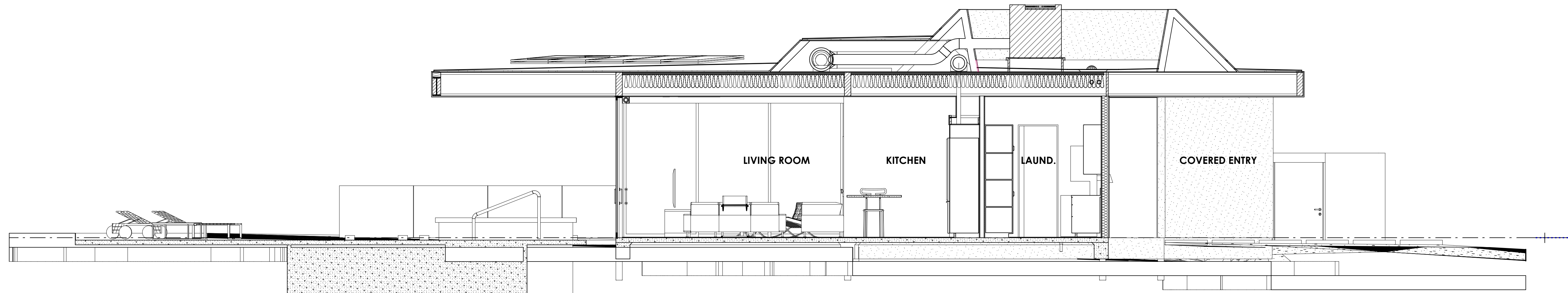

BUILDING SECTION F/A8.1

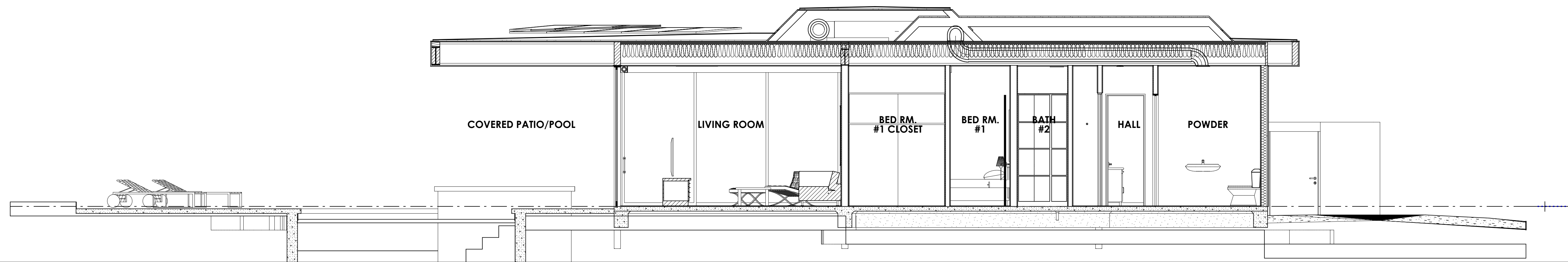

BUILDING SECTION G/A8.1

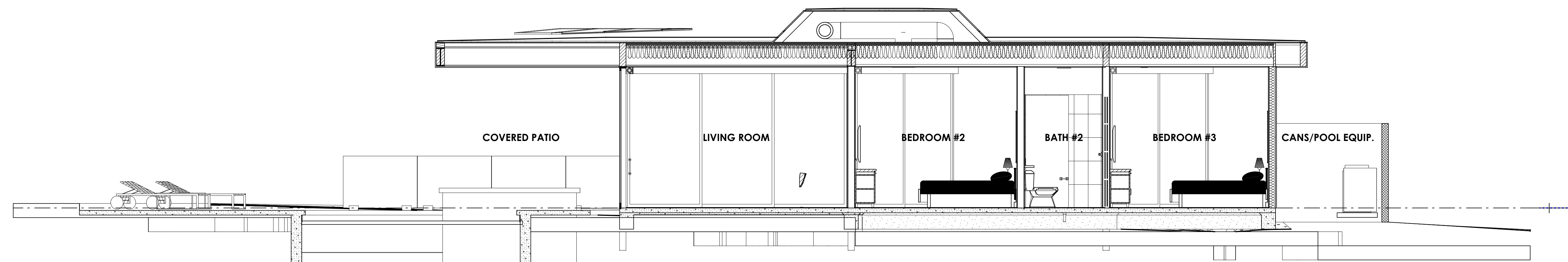

BUILDING SECTION H/A8.1

REVISIONS
RESIDENTIAL DESIGN BY:
JONATHAN PELEZZARE
44599 Pelton Blvd, SPC 14
Yucca Valley, CA 92089
Phone: (760) 371-2748
Email: info@jonathandesign.com

BUILDING SECTIONS E THRU I

A custom residence for:
Yucca Valley, CA

DRAWN:
CHECKED:
DATE: 5/30/2026
SCALE: 1/4" = 1'-0" (UNIFORM)
JOB #:
SHEET NO.:
A8.1
OF 43 SHEETS

SPECIAL INSULATION NOTES:

All roof joist cavity spaces over living areas are "UN-VENTED" and are to receive minimum 2" thickness of "Energysield CGF PRO" insulation board (@ R-6 per inch thickness) placed against (in contact with) the underside of the ply wd. roof sheathing w/ typical R-38 fiberglass bat insulation directly under and against (in contact with) the CGF insulation board as indicated on the first building section of each sheet (total insulation value = R-50). Indicates Energysield CGF PRO insulation board. Indicates R-38 fiberglass batt insulation.

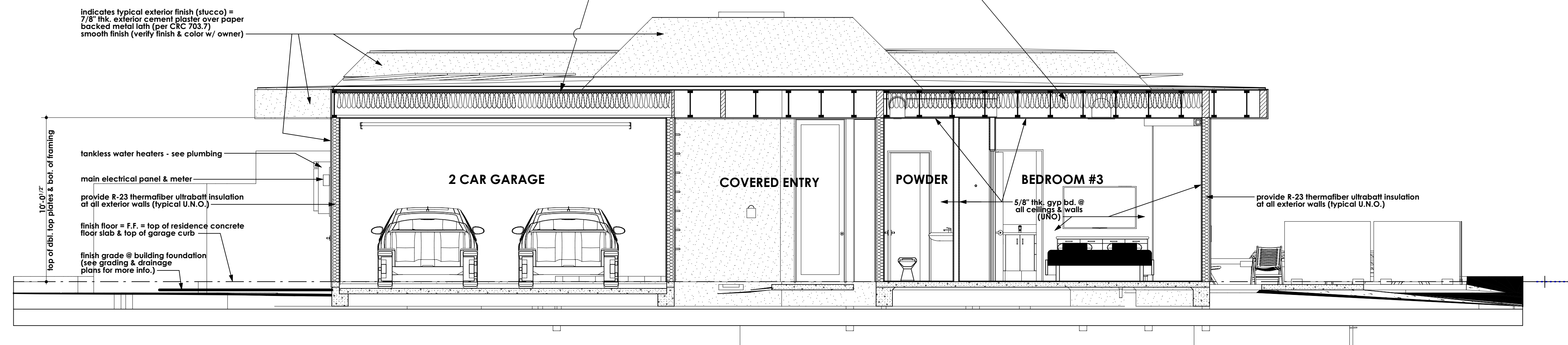

BUILDING SECTION I/A8.2

SCALE: 1/4" = 1'-0"

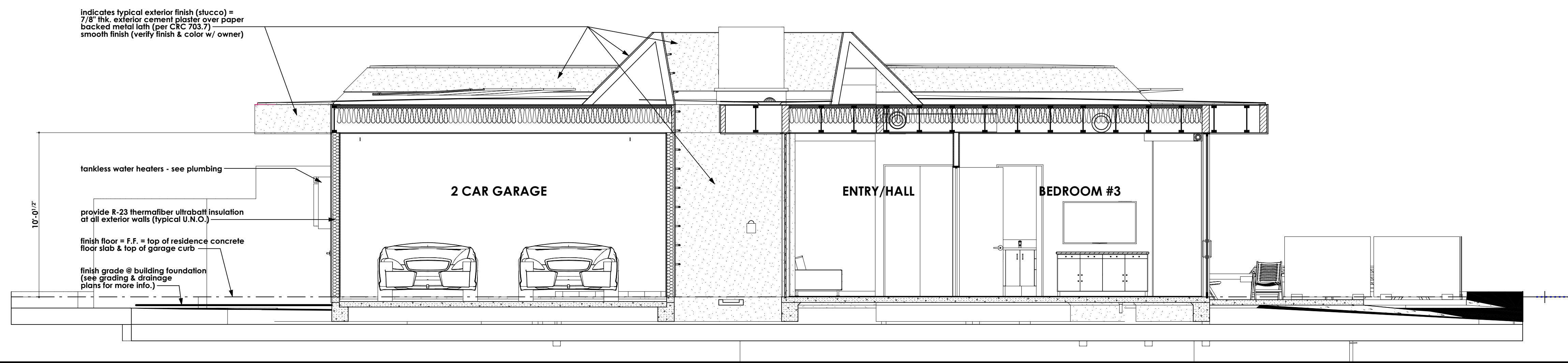

BUILDING SECTION J/A8.2

SCALE: 1/4" = 1'-0"

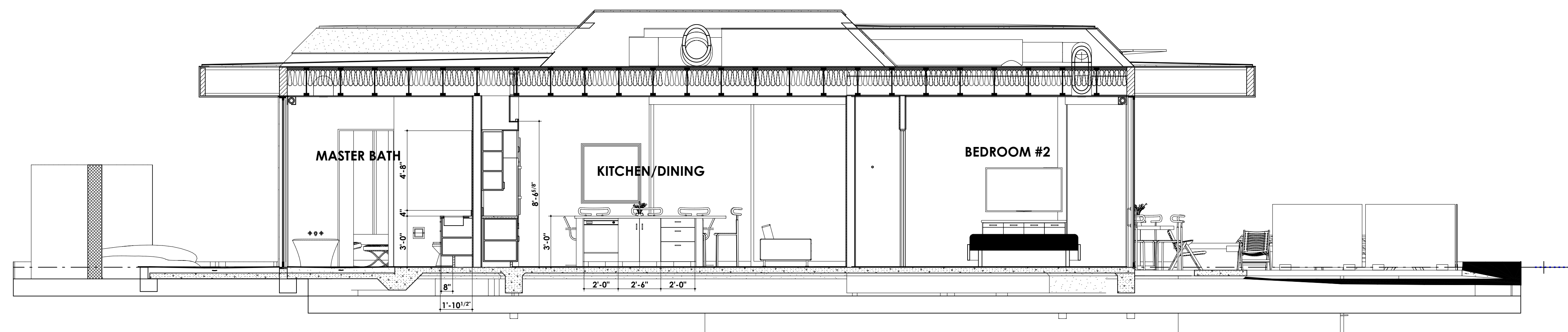

BUILDING SECTION K/A8.2

SCALE: 1/4" = 1'-0"

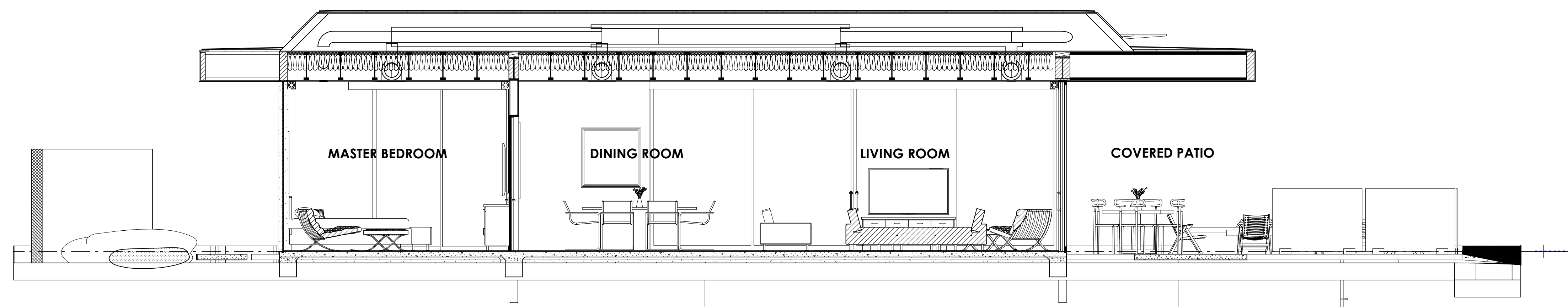

BUILDING SECTION L/A8.2

SCALE: 1/4" = 1'-0"

REVISIONS
 RESIDENTIAL DESIGN BY:
JONATHAN PELEZZARE
 4459 Person Blvd, Suite 110
 Yucca Valley, CA 92388
 Phone: (760) 371-2748
 Email: info@jonathandesign.com

BUILDING SECTIONS J THRU M

A custom residence for:
 Yucca Valley, CA

DRAWN:
 CHECKED:
 DATE: 5/30/2024
 SCALE: 1/4" = 1'-0" (UNIFORM)
 JOB #:
 SHEET NO.:
A8.2
 OF 43 SHEETS

SPECIAL INSULATION NOTES:
 All roof joist cavity spaces over living areas are "UN-VENTED" and are to receive minimum 2" thickness of "Energyshield CGF PRO" insulation board (@ R-6 per inch thickness) placed against (in contact with) the underside of the ply wd. roof sheathing w/ typical R-38 fiberglass bat insulation directly under and against (in contact with) the CGF insulation board as indicated on the first building section of each sheet (total insulation value = R-50).
 Indicates Energyshield CGF PRO insulation board
 Indicates R-38 fiberglass batt insulation

Indicates typical exterior finish (stucco) = 7/8" thk. exterior cement plaster over paper backed metal lath (per CBC 703.7) smooth finish (verify finish & color w/ owner)

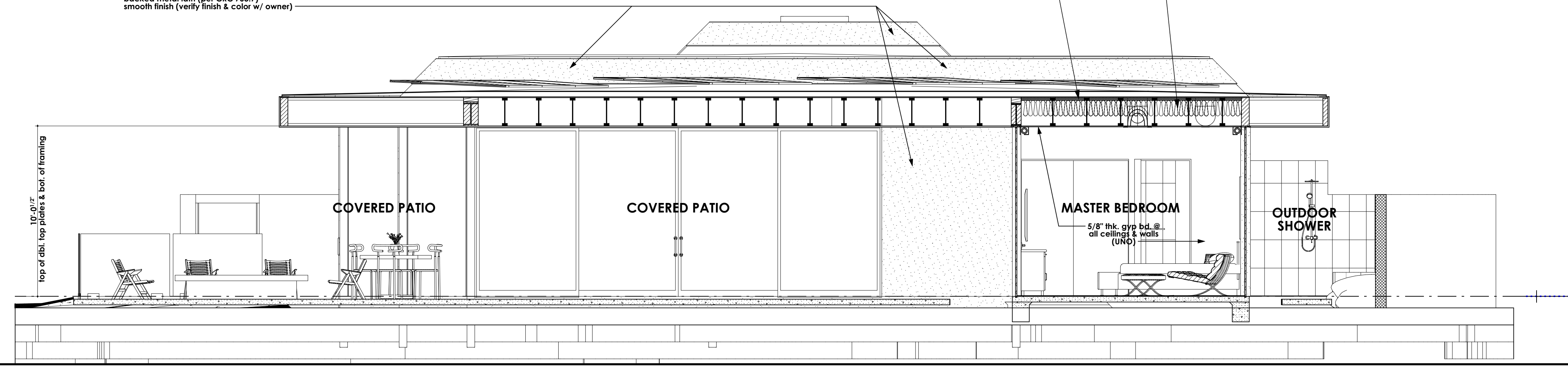

BUILDING SECTION M/A8.3

SCALE: 1/4" = 1'-0"

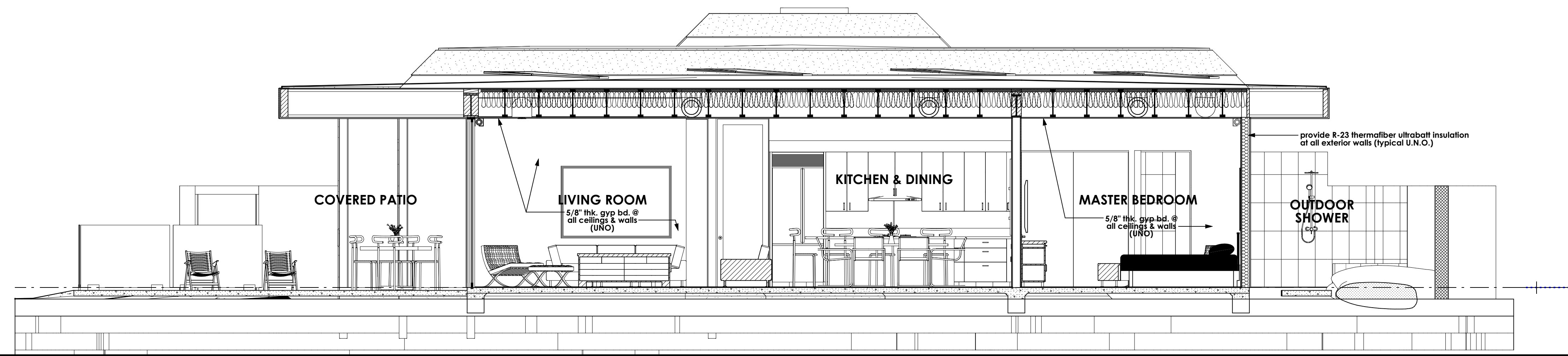
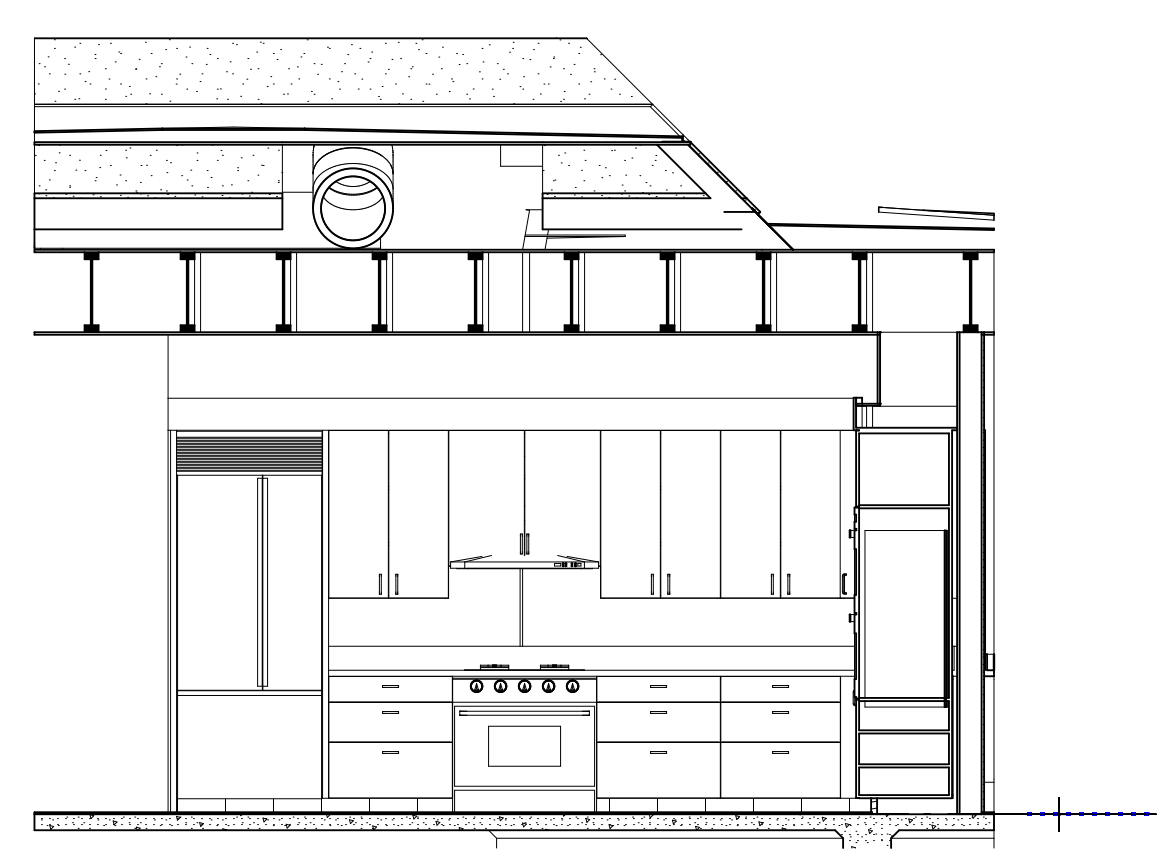

BUILDING SECTION Nα/A8.3

BUILDING SECTION N/A8.3

SCALE: 1/4" = 1'-0"



BUILDING SECTION P/A8.3

SCALE: 1/4" = 1'-0"



BUILDING SECTION Q/A8.3

SCALE: 1/4" = 1'-0"

REVISIONS
 RESIDENTIAL DESIGN BY:
JONATHAN PELEZZARE
 4459 Persimmon Blvd, Suite 114
 Yucca Valley, CA 92086
 Phone: (760) 371-2748
 Email: info@jonathandesign.com

BUILDING SECTIONS N THRU S

A custom residence for:
Yucca Valley, CA

DRAWN:
 CHECKED:
 DATE: 5/30/2026
 SCALE: 1/4" = 1'-0" (UNO)
 JOB #:
 SHEET NO.:
A8.3
 OF 43 SHEETS

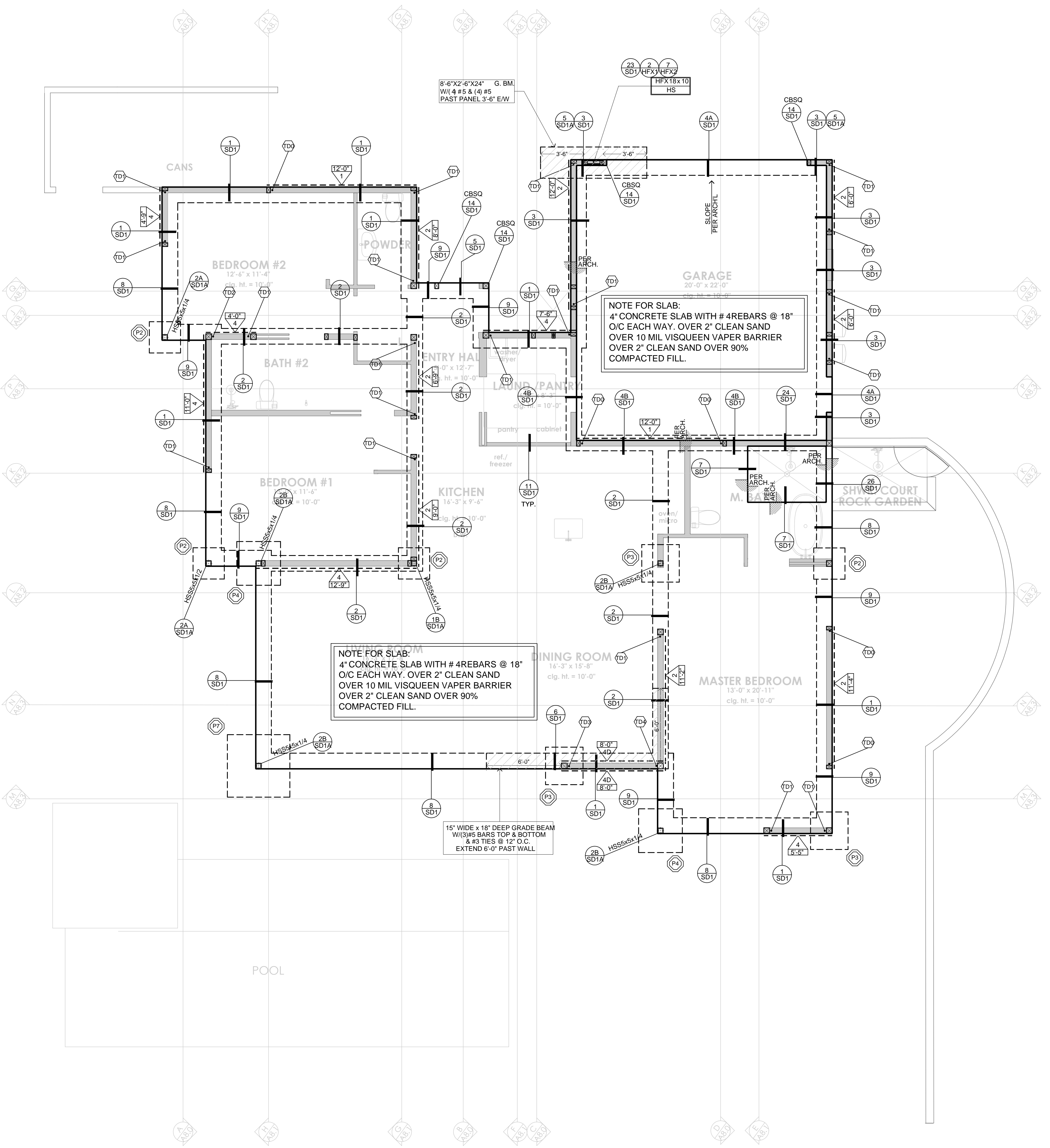

SYMBOLS LEGEND

	FOOTING
	DROP IN SLAB (VERIFY PRIOR TO CONSTRUCTION)
	PAD NUMBER
	SHEAR PANEL LENGTH AND NUMBER. REFER TO GN FOR PANEL TYPE, MIN. 2-24 @ EA. END.
	DETAIL NUMBER DETAIL SHEET NUMBER
	HOLDOWN NUMBER
	WOOD WALL
	CMU WALL

PAD SCHEDULE

SYM.	PAD TYPE
(1)	2'-0" SQ. X 15" DEEP PAD W/ #5 BARS @ 9" O.C. E.W.
(2)	2'-6" SQ. X 15" DEEP PAD W/ #5 BARS @ 12" O.C. E.W.
(3)	3'-0" SQ. X 15" DEEP PAD W/ #5 BARS @ 12" O.C. E.W.
(4)	3'-6" SQ. X 15" DEEP PAD W/ #5 BARS @ 12" O.C. E.W.
(5)	4'-0" SQ. X 15" DEEP PAD W/ #5 BARS @ 12" O.C. E.W.
(6)	4'-6" SQ. X 15" DEEP PAD W/ #5 BARS @ 12" O.C. E.W.
(7)	5'-0" SQ. X 18" DEEP PAD W/ #5 BARS @ 12" O.C. E.W. AT TOP & W/ #5 BARS @ 12" O.C. E.W. AT BOTTOM
(8)	5'-6" SQ. X 18" DEEP PAD W/ #5 BARS @ 12" O.C. E.W. AT TOP & W/ #5 BARS @ 12" O.C. E.W. AT BOTTOM

HOLDOWN SCHEDULE

SYM.	SIMPSON HOLDOWN	NOTES
(1)	HDU2	
(2)	HDU5	
(3)	HDU8	
(4)	HDU11	REFER TO DETAIL 19/SD1 (OR 4/SD1A FOR DUAL POUR CONDITION)
(5)	HDU14	
(6)	HHQ11	

FOUNDATION NOTES

- REFER TO GN & GD SHEETS FOR MORE INFORMATION.
 - FOR SHEAR PANEL TYPES 3, 4 & 5 ON BOTH SIDES OF WALL, USE MIN. 3X6 SILL PLATES U.N.O.
- NOTE:**
 CONTRACTOR IS RESPONSIBLE FOR VERIFYING HARDY FRAMES MATCH TOP PLATE HEIGHT & NOTIFY ENGINEER OF RECORD IF DIFFERENT THAN PLANS.
- SEE SHEETS HFX-1 & HFX-2 FOR MANUFACTURER INSTALLATION REQUIREMENTS
- NOTE:** TOP OF ALL EXTERIOR FOOTING, GRADE BEAM FOOTING, PAD FOOTING, OR FLAG POLE FOOTING TO BE MIN. 6" BELOW FINISH GRADE.

KEY NOTES

- IF FOOTING IS WIDER THAN 15", THEN PROVIDE #5 BAR @ 12" O/C, TOP & BOTTOM

SHEAR WALL SCHEDULE

2018 NATIONAL DESIGN SPECIFICATION - AMERICAN WOOD COUNCIL [2018 NDS](1)(3)

SHEAR PANEL TYPE	SHEATHING (S)	EDGE NAILING (COMMON) (E)	FIELD NAILING (COMMON) (F)	ALLOWABLE SHEAR (PLF)	SILL PLATE CONNECTION			FRAMING CLIPS A305, L550S OR LTP4S (S), (E)		
					16d SINKER	1 1/4" SDS SCREWS	5d x 3" LPS			
A	3/8" APA rnsd	8 d's @ 6" O.C.	8 d's @ 12" O.C.	290	(7) 220	@ 6" O.C.	@ 16" O.C.	48"	@ 16" O.C.	
		8 d's @ 4" O.C.	8 d's @ 12" O.C.	360	(7) 320	@ 4" O.C.	@ 12" O.C.	36"	48"	@ 12" O.C.
A	3/8" APA rnsd	8 d's @ 3" O.C.	8 d's @ 12" O.C.	450	(10) 410	@ 3" O.C.	@ 8" O.C.	24"	44"	@ 8" O.C. (10)
		8 d's @ 2" O.C.	8 d's @ 12" O.C.	640	(10) 530	@ 2" O.C.	@ 6" O.C.	18"	32"	@ 6" O.C. (10)
A	1 1/2" APA rnsd Structural I	10 d's @ 2" O.C.	10 d's @ 12" O.C.	870	N/A	@ 5" O.C.	N/A	16"	@ 6" O.C. (10)	
		8 d's @ 3" O.C. each side	8 d's @ 12" O.C. each side	990	(7) 820	N/A	@ 4" O.C.	N/A	22"	LTP4 @ 8" O.C. (12) EACH SIDE (13)
A	3/8" APA rnsd	8 d's @ 2" O.C. each side	8 d's @ 12" O.C. each side	1280	(7) 1060	N/A	@ 3" O.C.	N/A	16"	LTP4 @ 8" O.C. (12) EACH SIDE (13)

- SHEATHING PANEL JOINT AND SILL PLATE NAILING SHALL BE STAGGERED IN ALL CASES.
- PROVIDE 3" NOMINAL OR WIDER FRAMING AT ADJOINING PANEL EDGES WITH NAILS STAGGERED.
- STUDS ARE SPACED @ 16" O.C. MAX. UNLESS NOTED OTHERWISE ON PLAN.
- PERIODIC SPECIAL INSPECTION IS REQUIRED.
- USE CLIPS @ 6" O.C. ON SIMPSON STRONG WALL & HARDY FRAME (U.N.O.).
- USE SPACING PER SCHEDULE IF NUMBER OF FRAMING CLIPS ARE NOT SPECIFIED ON FRAMING PLANS.
- ALLOWABLE SHEAR ARE FOR STUDS SPACED @ 24" O.C. MAX.
- SHEATHING CONFORMS TO EITHER DOC PS 1 OR PS 2 STANDARDS.
- NAILING @ 6" O.C. WHEN STUDS ARE SPACED @ 24" O.C.
- FOR DOUBLE SIDED SHEAR PANELS:
 - USE HALF THE SPACING OF SILL PLATE FASTENERS STAGGERED FOR TYPE A
 - USE ONLY 1/4" x 3/8" SDS SCREWS IN SCHEDULE AND WITH HALF THE SPACING.
- FOR TYPES A, A, & A:
 - USE SHEAR TRANSFER DETAIL ON PLAN FOR FRAMING CLIP TYPES AND SPACING.
- FOR TYPES A, A, & A:
 - EXTRA SHEAR PANEL FOR RIGIDITY
- FOR SHEAR PANEL TYPES 3, 4 & 5 ON BOTH SIDES OF WALL, USE MIN. 3X6 SILL PLATES U.N.O.
- USE 8d COMMON NAILS FOR LTP4 INSTALLED OVER SHEATHING.
- CLIPS ARE TO BE INSTALLED STAGGERED.

(3BD)

- A.B. ANCHOR BOLT
- ABV. ABOVE
- BAR. REINF. BAR
- BD. BOARD
- BLKG. BLOCKING
- BLW. BELOW
- BM. BEAM
- B.N. BOUNDARY NAIL
- B.O.B. BOTTOM OF BEAM
- B.O.J. BOTTOM OF JOIST
- B.O.T. BOTTOM OF JOIST
- E.W. EACH WAY
- CF. CEILING JOIST
- CJ. CONTINUOUS FOOTING
- COL. COLUMN
- CONC. CONCRETE
- CONT. CONTINUOUS
- C.P.E. CONT. PANEL
- D. DEPTH
- DBL. DOUBLE
- DF. DOUGLAS FIR
- DIA. DIAMETER
- DITTO DITTO
- E. EXISTING
- E.W. EACH WAY
- E.J. EXPANSION JOINT
- EN. EDGE NAIL
- EQ. EQUAL FLOOR BEAM
- F.G. FINISH GRADE
- FLOOR JOIST FLOOR JOIST
- FL. FLUSH
- FL. FRAMING
- F.N. FIELD NAIL
- F.O.C. FACE OF CONCRETE
- F.O.M. FACE OF MASONRY
- F.O.S. FACE OF STUDS
- F.P. FULL PENETRATION
- FTG. FOOTING
- GA. GALVE
- GALV. GALVANIZED
- GLB. GLUE-LAMINATED BEAM
- GR.BM. GRADE BEAM
- GW.B. Gypsum WALLBOARD
- H. HIGH
- HDR. HEADER
- HFX. HARDY FRAME
- HGT. HEIGHT
- HORIZ. HORIZONTAL
- K.P. KING POST
- LENGTH LENGTH
- LT.WT. LIGHT WEIGHT
- L.V.L. LAMINATED VENEER LUMBER
- M.S. MASONRY
- M.B. MACHINE BOLT
- MLB. MICRO-LAM BEAM
- (N) NEW
- N.G. NATURAL GRADE
- O/C ON CENTER
- P.J. POUR JOINT
- PLB. PARALLAM BEAM
- PLWD. PLYWOOD
- P.T. PRESSURE TREATED
- RF. ROOF BEAM
- R.B. ROOF BEAM
- REINF. REINFORCING
- REQD. REQUIRED
- RF. ROOF
- RF. ROOF RAFTER
- T.O.B. TOP OF BEAM
- V.I.F. VERIFY IN FIELD

DESIGNER:
 Jonathan Pelezzare

DEVELOPER:
 N/A

ADDRESS:

REVISIONS

NO.	DATE	DESCRIPTION

SHEET NAME:
 FOUNDATION PLAN

PROJECT NUMBER:
 220653

DESIGNED BY: CHECKED BY:
 R.A./H.K. R.A.

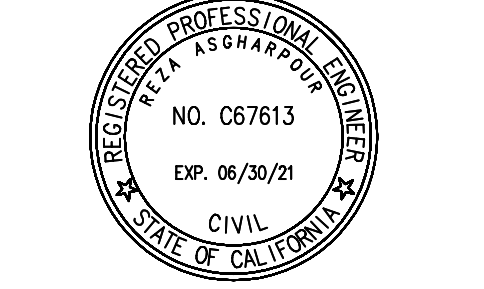

PLOT DATE:
 08/23/2022

SHEET NUMBER:
 S-1

FOUNDATION PLAN

SCALE : 1/4" = 1'-0"

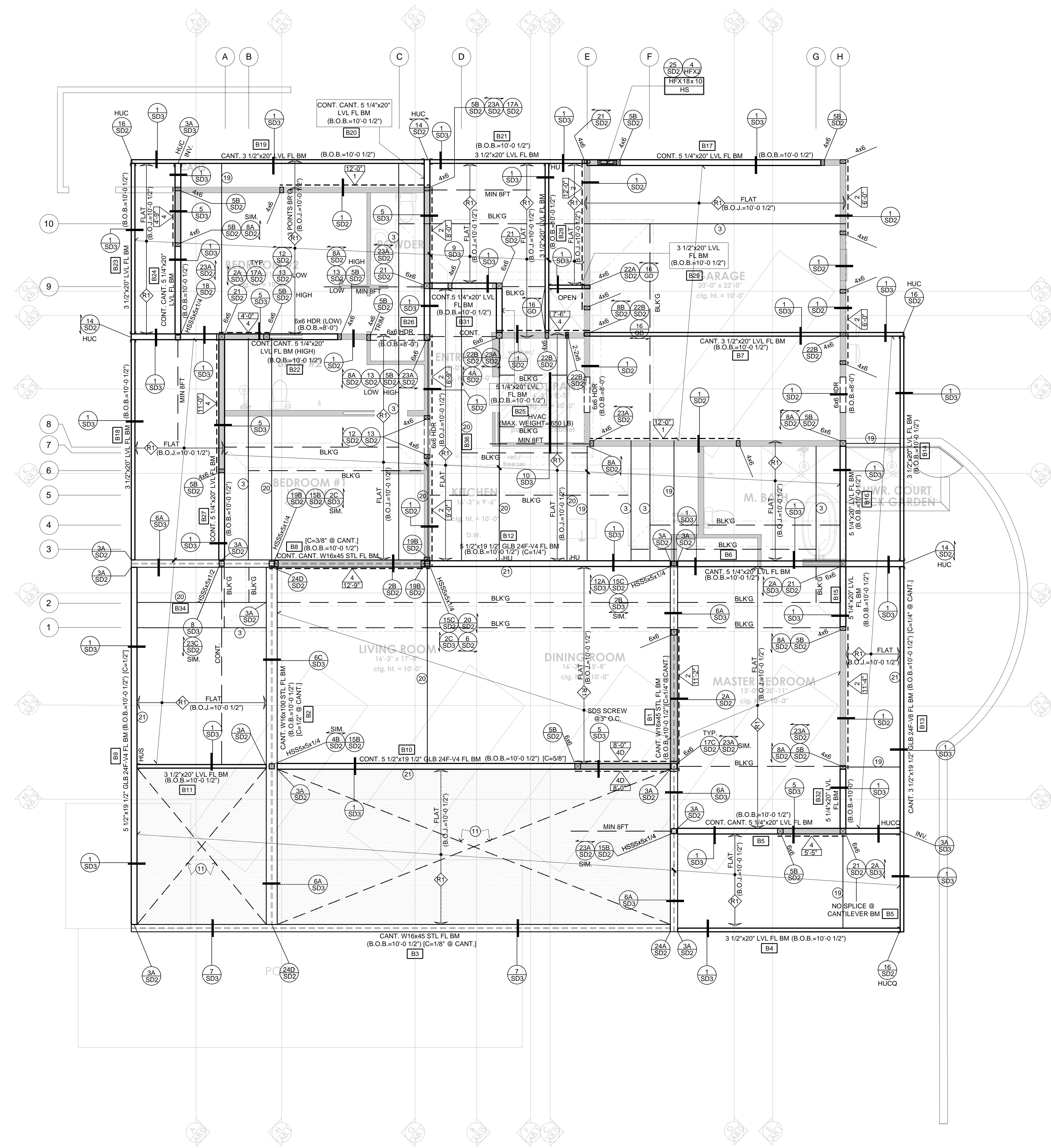

LOW ROOF FRAMING PLAN

SCALE: 1/4" = 1'-0"

SHEAR WALL SCHEDULE

2018 NATIONAL DESIGN SPECIFICATION - AMERICAN WOOD COUNCIL [2018 NDS(11)(3)]

SHEAR PANEL TYPE	SHEATHING (S)	EDGE NAILING (COMMON)	FIELD NAILING (COMMON)	ALLOWABLE SHEAR (PLF)	SILL PLATE CONNECTION (PLF)	FRAMING CLIPS A308, L5501 OR LTP4 (S)
1	3/8" APA rated	8 d's @ 8" O.C.	8 d's @ 12" O.C.	200 (7) 220 (7)	16d's @ 8" O.C. @ 16" O.C. @ 12" O.C.	16" @ 16" O.C.
2	3/8" APA rated	8 d's @ 8" O.C.	8 d's @ 12" O.C.	300 (7) 320 (7)	16d's @ 8" O.C. @ 16" O.C. @ 12" O.C.	16" @ 16" O.C.
3	3/8" APA rated	8 d's @ 8" O.C.	8 d's @ 12" O.C.	400 (7) 410 (7)	16d's @ 8" O.C. @ 16" O.C. @ 12" O.C.	16" @ 16" O.C.
4	3/8" APA rated	8 d's @ 8" O.C.	8 d's @ 12" O.C.	640 (7) 530 (7)	16d's @ 8" O.C. @ 16" O.C. @ 12" O.C.	16" @ 16" O.C.
5	1/2" APA rated	10 d's @ 8" O.C.	10 d's @ 12" O.C.	870 (7) 820 (7)	16d's @ 8" O.C. @ 16" O.C. @ 12" O.C.	16" @ 16" O.C.
6	3/8" APA rated	8 d's @ 8" O.C.	8 d's @ 12" O.C.	900 (7) 820 (7)	16d's @ 8" O.C. @ 16" O.C. @ 12" O.C.	16" @ 16" O.C.
7	3/8" APA rated	8 d's @ 8" O.C.	8 d's @ 12" O.C.	1280 (7) 1060 (7)	16d's @ 8" O.C. @ 16" O.C. @ 12" O.C.	16" @ 16" O.C.

- SHEATHING PANEL JOINT AND SILL PLATE NAILING SHALL BE STAGGERED IN ALL CASES.
- PROVIDE 3" NOMINAL OR WIDER FRAMING AT ADJOINING PANEL EDGES WITH NAILS STAGGERED.
- STUDS ARE SPACED @ 16" O.C. MAX. UNLESS NOTED OTHERWISE ON PLAN.
- PERIODIC SPECIAL INSPECTION IS REQUIRED.
- USE CLIPS @ 6" O.C. ON SIMPSON STRONG WALL & HARDY FRAME (U.N.O.)
- USE SPACING PER SCHEDULE IF NUMBER OF FRAMING CLIPS ARE NOT SPECIFIED ON FRAMING PLANS.
- ALLOWABLE SHEAR ARE FOR STUDS SPACED @ 24" O.C. MAX.
- SHEATHING CONFORMS TO EITHER DOC PS 1 OR PS 2 STANDARDS.
- NAILING @ 8" O.C. WHEN STUDS ARE SPACED @ 24" O.C.
- FOR DOUBLE SIDED SHEAR PANELS:
 - USE HALF THE SPACING OF SILL PLATE FASTENERS STAGGERED FOR TYPE 1
 - USE ONLY 1/4" DIA. SDS SCREWS IN SCHEDULE AND WITH HALF THE SPACING.
- SEE SHEAR TRANSFER DETAIL ON PLAN FOR FRAMING CLIP TYPES AND SPACING.
- EXTRA SHEAR PANEL FOR RIGIDITY
- USE 8d COMMON NAILS FOR LTP4 INSTALLED OVER SHEATHING. USE MIN. 3x6 SILL PLATES U.N.O.
- USE 8d COMMON NAILS FOR LTP4 INSTALLED OVER SHEATHING.
- CLIPS ARE TO BE INSTALLED STAGGERED.

SYMBOLS LEGEND

- POST OR TRIMMER AS NOTED
- DIRECTION OF ROOF MEMBER PER SCHEDULE. REFER TO HATCHED WALLS ON PLANS FOR INTERMEDIATE BR'G
- DIRECTION OF FLOOR MEMBER PER SCHEDULE. REFER TO HATCHED WALLS ON PLANS FOR INTERMEDIATE BR'G
- DIRECTION OF DECK OR ROOF RAFTERS MEMBER PER SCHEDULE. REFER TO HATCHED WALLS ON PLANS FOR INTERMEDIATE BR'G
- SHEAR PANEL LENGTH AND NUMBER. REFER TO GN FOR PANEL TYPE. MIN. 2-2x4 @ EA. END.
- DETAIL NUMBER DETAIL SHEET NUMBER
- BEAM NUMBER, REFER TO E.O.R. CALCULATIONS
- KEY NOTE NUMBER
- CALIFORNIA FRAMING
- FLOOR TO FLOOR HOLDOWN PER SCHEDULE BELOW:
- FLOOR TO FLOOR HOLDOWN PER SCHEDULE BELOW:
- FLOOR TO FLOOR HOLDOWN PER SCHEDULE BELOW:
- FLOOR TO FLOOR HOLDOWN PER SCHEDULE BELOW:

KEY NOTES

- ALIGN STUD(S) / POST(S) WITH UPPER FLOOR STUD(S) / POST(S) AND PROVIDE SOLID BLOCKING BETWEEN FLOOR (PROVIDE E.N. WHEN POST IS LOCATED WITHIN S.W.)
- PROVIDE SOLID BLOCKING
- CONTINUOUS JOIST W/ E.N.
- DRAG TRUSS W/E.N. TRUSS TO TRANSFER 1650W FORCE MIN. (U.N.O.)
- SHEAR TRUSS W/E.N. TRUSS TO TRANSFER 200 PLF MIN. (U.N.O.)
- LINE OF 2x4 BLOCKING W/ EDGE NAIL, & CONTINUOUS CS16 STRAP OVER U.N.O. SEE PLAN FOR NUMBER OF BAYS.
- CONTINUOUS FULL HT. BLKG. W/E.N. SEE PLANS FOR NUMBER OF BAYS (U.N.O.)
- TRUSS HANGER BY TRUSS SUPPLIER
- (1) SIMPSON TS22 FLUSH BEAM TO DRIP BEAM (U.N.O.)
- BLOCKED FLOOR DIAPHRAGM W/ 10d's @ 4" O.C. B.N., 6" O.C. E.N. & 12" O.C. FIELD.
- BLOCKED FLOOR DIAPHRAGM W/ 10d's @ 2 1/2" O.C. B.N., 4" O.C. E.N. & 12" O.C. FIELD.
- PROVIDE SIMPSON STRAP @ SPLICE
- UNDER SHEAR WALL ABOVE W/ (1) CS16, U.N.O.
- DRAG STRUT W/E.N. SEE PLANS/DETAILS FOR LENGTH, SUPPORT END W/ BLKG'S
- TRUSS DESIGNER TO CONSIDER ADDITIONAL #PSF DEAD LOAD FOR FUTURE SOLAR PANELS IN DESIGN.
- TRUSS DESIGNER TO CONSIDER WEIGHT OF WALL ABOVE. IF STUCCO, THEN CONSIDER 17 PSF. IF STONE VENEER, THEN CONSIDER 32 PSF.
- CUSTOM HEIGHT HARDY FRAME TO MATCH FIELD CONDITION, CONTRACTOR TO VERIFY HEIGHT PRIOR TO ORDER / TOP OF HARDY FRAME SHOULD BE BOTTOM OF BEAM SEE DETAIL 31/503
- PROVIDE 3 1/4" X F.H. LVL W/E.N
- PROVIDE 3 1/2" X F.H. LVL W/E.N
- USE 10 d's NAILS FOR B.N. & E.N. & F.N. WHERE 1/2" THICK FILLER APPLIED TO T.O.B.
- USE FOAM ROOF ONLY (MAX 16 PSF TOTAL DEAD LOAD)

FRAMING SCHEDULE

- 20" TJI 360 ROOF JOISTS @ 24" O.C.
- 2 x 8 ROOF JOISTS / RAFTERS @ 16" O.C.

FRAMING NOTES

- REFER TO GN & GD SHEETS FOR MORE INFORMATION.
- REFER TO DETAIL 3/1GD FOR TYPICAL CONNECTION AT ALL INTERIOR NON-BEARING WALLS AT ROOF LEVEL.
- SHEAR WALLS CANNOT BE USED AS PLUMBING WALLS, UNLESS APPROVED BY E.O.R. IN WRITING.
- AT DOUBLE SIDED SHEAR WALLS, POST W/E.N. PER PLAN TO RECEIVE E.N. FROM BOTH SIDES.
- WHEN MULTIPLE STUDS ARE USED INSTEAD OF A SINGLE POST, PLYWOOD SHEAR WALL TO BE NAILED TO ALL STUDS RECEIVING HOLDOWNS.
- APPLY SHEAR PRIOR TO FRAMING OF PERPENDICULAR WALLS. DO NOT BREAK SHEAR AT PERPENDICULAR WALL LOCATIONS UNLESS SPECIFICALLY DETAILED ON PLANS.
- ALL VERTICAL PIPES THROUGH PLANS AND/OR SOLID RIM BEAMS MUST BE DRILLED CLEAN CUT W/ 1/16" TOLERANCE. DO NOT NOTCH OR CUT PLANS.
- ALL BEAMS SHOWN ARE DROP (U.N.O.) ON PLANS.
- USE SIMPSON "IUS" HANGERS FOR CONNECTION OF I-JOISTS TO OTHER FRAMING MEMBERS (U.N.O.) AND "LUS" HANGERS FOR CONNECTION OF SOLID JOISTS.
- ALL WOOD I-JOISTS SHALL BE IN COMPLIANCE WITH THE PROVISIONS OF APA PRI-400, EWS-2725B (PERFORMANCE RATED I-JOIST STANDARD) OR ASTM D5055, QUALIFIED PRI-400, MANUFACTURED. SUBMIT SHOP DRAWING TO E.O.R. FOR REVIEW AND APPROVAL.
- A 4x6 HEADER SHOULD BE USED AT ALL OPENINGS IN EXTERIOR & INTERIOR BEARING WALLS (U.N.O.) ON PLANS. ALL 4x6 TO 4x12 SIZES CAN BE SUBSTITUTED WITH A 2-2x TO MATCH THE DEPTH AND THE 2-2x SHALL BE PLACED ON END WITH 1/2" PLYWOOD SHIM BETWEEN. PROVIDE 16d NAILS @ 16" O.C., STAGG., BOTH SIDES.
- USE 2X TRIMMER FOR HEADERS LESS THAN 6'-0" AND 2-2X FOR 6'-0" TO 10'-0" LONG SPAN IN BEARING WALLS, U.N.O. ON THE PLAN. REQUIRED TRIMMER MUST BE APPLIED @ EACH END OF HEADER. SEE PLANS FOR HEADERS LARGER THAN 10'-0" LONG.
- INTERIOR NON-BEARING WALLS MAY BE FRAMED WITH 2x STUDS AT 24" O.C. MAX.
- TOP PLATES AT ALL ROOF FRAMING LEVELS SHOULD BE SPICED PER 9d/SD2 U.N.O. ON PLANS.
- CONTINUOUS 1 1/2" LVL RIM JOISTS SHOULD BE USED AT ALL FLOOR FRAMING EDGES WHERE POSSIBLE. ALL RIM BREAKS SHOULD BE SPICED WITH A SINGLE CS16 X36" STRAP, PER 44/402 U.N.O. ON PLANS.
- ALL SIMPSON LEG/MEG/EG HANGERS SHALL BE ORDERED W/TOP FLANGE.

NOTE: CONTRACTOR IS RESPONSIBLE FOR VERIFYING HARDY FRAMES MATCH TOP PLATE HEIGHT & NOTIFY ENGINEER OF RECORD IF DIFFERENT THAN PLANS.
SEE SHEETS HFX-1 & HFX-2, HFX3 FOR MANUFACTURER INSTALLATION REQUIREMENTS.

I-JOIST CONVERSION TABLE

MANUFACTURER	I LEVEL BY WETHERHOLSER	ROSEBURG	ROSE CASCADE
ICC-ES REPORT	ESR-1153	ESR-1251	ESR-1336
11 7/8"	TJ 210	RFR-400	BCI 6005-1.2
DEPTH	TJ 360	RFR-70	BCI 602-2.0
14" TO 18"	TJ 560	RFR-50	BCI 602-2.0
	TJ 210	RFR-400	BCI 6005-1.8
	TJ 360	RFR-70	BCI 602-2.0
	TJ 560	RFR-50	N/A

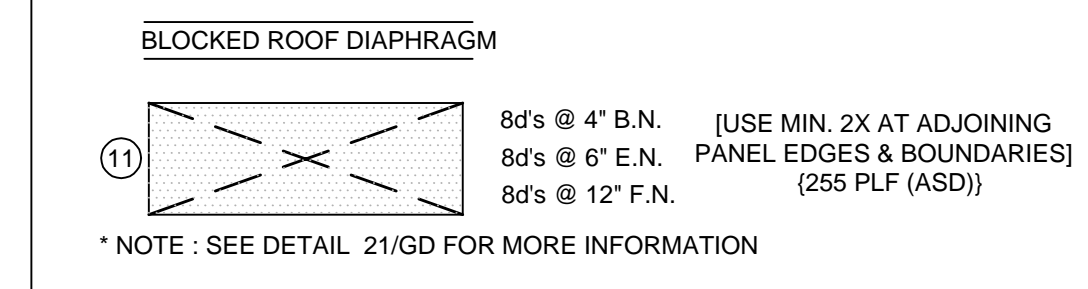

* NOTE: SEE DETAIL 21/1GD FOR MORE INFORMATION

RA STRUCTURAL ENGINEERING, INC.
 REZA ASGHARPOUR, P.E.
 77570 SPRINGFIELD LANE,
 SUITE D
 PALM DESERT, CA 92211
 PHONE: 760-360-9998
 FAX: 760-360-9903
 EMAIL: REZA@RASTRUCTURAL.COM
 PROJECT NAME:

(3BD)

- A.B. ANCHOR BOLT ABOVE
- ABV. REIN. BAR
- BD. BOARD
- BLKG. BLOCKING BELOW
- BLW. BEAM
- BM. BOUNDARY NAIL
- B.N. BOTTOM OF BEAM
- B.O.B. BOTTOM OF JOIST
- B.O.T. BOTTOM OF JOIST
- E.W. EACH WAY
- CF. CONTINUOUS FOOTING
- CJ. CEILING JOIST
- COL. COLUMN
- CONC. CONCRETE
- CONT. CONTINUOUS
- CONT. PANEL CONT. PANEL
- D. DEPTH
- DBL. DOUBLE
- DF. DOUGLAS FIR
- DIA. DIAMETER
- DD. DITTO
- EXIST. EXISTING
- E.W. EACH WAY
- E.J. EXPANSION JOINT
- E.N. EDGE NAIL
- EQ. EQUAL FLOOR BEAM
- FG. FINISH GRADE
- F.F. FLOOR JOIST
- FL. FLUSH
- F.M.G. FRAMING
- F.N. FIELD NAIL
- F.O.C. FACE OF CONCRETE
- F.O.M. FACE OF MASONRY
- F.O.S. FACE OF STUDS
- F.P. FULL PENETRATION
- FTG. FOOTING
- GA. GAUGE
- GALV. GALVANIZED
- GLB. GLUE-LAMINATED BEAM
- GR.BM. GRADE BEAM
- GW.B. GYPSUM WALLBOARD
- H. HIGH
- HDR. HEADER
- HFX. HARDY FRAME
- HGT. HEIGHT
- HORIZ. HORIZONTAL
- K.P. KING POST
- LENG. LENGTH
- LT.WT. LIGHT WEIGHT
- L.V.L. LAMINATED VENEER LUMBER
- M.A.S. MASONRY
- M.B. MACHINE BOLT
- MLB. MICRO-LAM BEAM
- (N) NEW
- N.G. NATURAL GRADE
- O/C. ON CENTER
- P.J. POUR JOINT
- P.L.B. PARALLAM BEAM
- PL.W.D. PLYWOOD
- P.T. PRESSURE TREATED
- R.B. ROOF BEAM
- REINF. REINFORCING
- REQD. REQUIRED
- RF. ROOF
- RR. ROOF RAFTER
- T.O.B. TOP OF BEAM
- V.I.F. VERIFY IN FIELD

DESIGNER:
Jonathan Pelezzare

DEVELOPER:
N/A

ADDRESS:

REVISIONS

NO.	DATE	DESCRIPTION

SHEET NAME:
LOW ROOF FRAMING PLAN

PROJECT NUMBER:
220653

DESIGNED BY: CHECKED BY:
R.A./H.K. R.A.

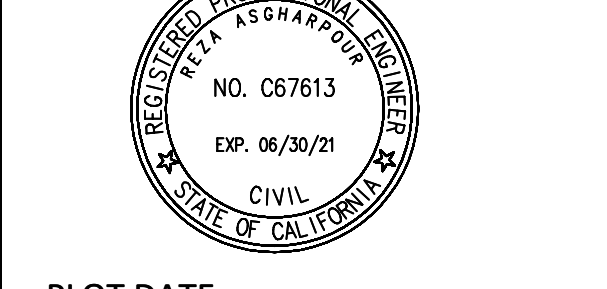

PLOT DATE:
08/23/2022

SHEET NUMBER:
S-2

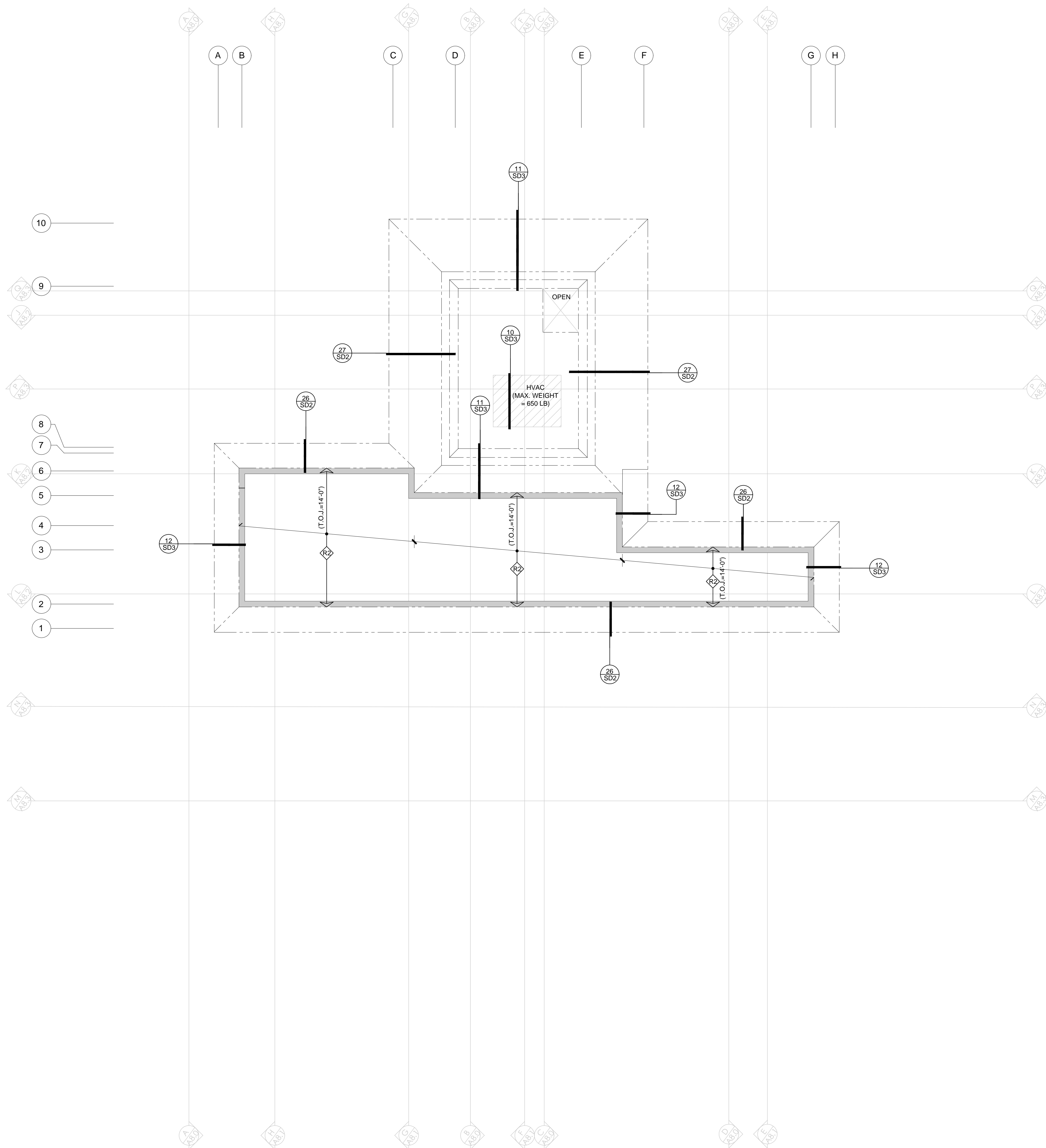

HIGH ROOF FRAMING PLAN

SCALE: 1/4" = 1'-0"

SHEAR WALL SCHEDULE

2018 NATIONAL DESIGN SPECIFICATION - AMERICAN WOOD COUNCIL [2018 NDS](11/3)

SHEAR PANEL TYPE	SHEATHING (B)	EDGE NAILING (COMMON)	FIELD NAILING (COMMON)	ALLOWABLE SHEAR (PLF)	SILL PLATE CONNECTION			FRAMING CLIPS A308, L550 OR LTP4 (9)
					166S SINKER	146S/156S SCREWS	66C B.A.B. SPCG	
△ (1)	3/8" APA rated	8 d's @ 8" O.C.	8 d's @ 12" O.C.	200 (7) 220 (7)	@ 8" O.C.	@ 16" O.C.	2x 3x	@ 16" O.C.
△ (2)	3/8" APA rated	8 d's @ 4" O.C.	8 d's @ 12" O.C.	300 (7) 320 (7)	@ 4" O.C.	@ 12" O.C.	36" 48"	@ 12" O.C.
△ (3)	3/8" APA rated	8 d's @ 3" O.C.	8 d's @ 12" O.C.	400 (7) 410 (7)	@ 3" O.C.	@ 8" O.C.	24" 44"	@ 8" O.C.
△ (4)	3/8" APA rated	8 d's @ 2" O.C.	8 d's @ 12" O.C.	640 (7) 630 (7)	@ 2" O.C.	@ 6" O.C.	18" 32"	@ 6" O.C.
△ (5)	15/32" APA rated Structural I	10 d's @ 2" O.C.	10 d's @ 12" O.C.	870	N/A	@ 6" O.C.	N/A 16"	@ 6" O.C.
△ (6)	3/8" APA rated each side	8 d's @ 3" O.C.	8 d's @ 12" O.C.	900 (7) 820 (7)	N/A	@ 4" O.C.	N/A 22"	LTP4 @ 8" O.C. (12) EACH SIDE (13)
△ (7)	3/8" APA rated each side	8 d's @ 2" O.C.	8 d's @ 12" O.C.	1280 (7) 1060 (7)	N/A	@ 3" O.C.	N/A 16"	LTP4 @ 8" O.C. (12) EACH SIDE (13)

- SHEATHING PANEL JOINT AND SILL PLATE NAILING SHALL BE STAGGERED IN ALL CASES.
- PROVIDE 3" NOMINAL OR WIDER FRAMING AT ADJOINING PANEL EDGES WITH NAILS STAGGERED. STUDS ARE SPACED @ 16" O.C. MAX. UNLESS NOTED OTHERWISE ON PLAN.
- PERIODIC SPECIAL INSPECTION IS REQUIRED.
- USE CLIPS @ 6" O.C. ON SIMPSON STRONG WALL & HARDY FRAME (U.N.O.)
- USE SPACING PER SCHEDULE IF NUMBER OF FRAMING CLIPS ARE NOT SPECIFIED ON FRAMING PLANS.
- ALLOWABLE SHEAR ARE FOR STUDS SPACED @ 24" O.C. MAX.
- SHEATHING CONFORMS TO EITHER DGC PS 1 OR PS 2 STANDARDS.
- NAILING @ 6" O.C. WHEN STUDS ARE SPACED @ 24" O.C.
- FOR DOUBLE SIDED SHEAR PANELS:
 - USE HALF THE SPACING OF SILL PLATE FASTENERS STAGGERED FOR TYPE △
 - USE ONLY 146S/156S SCREWS IN SCHEDULE AND WITH HALF THE SPACING.
- EXTRA SHEAR PANEL FOR RIGIDITY
- FOR SHEAR PANEL TYPES 3, 4 & 5 ON BOTH SIDES OF WALL, USE MIN. 3x6 SILL PLATES U.N.O.
- USE 8d COMMON NAILS FOR LTP4 INSTALLED OVER SHEATHING.
- CLIPS ARE TO BE INSTALLED STAGGERED.

SYMBOLS LEGEND

- POST OR TRIMMER AS NOTED
- ◇ DIRECTION OF ROOF MEMBER PER SCHEDULE. REFER TO HATCHED WALLS ON PLANS FOR INTERMEDIATE BR'G
- ◇ DIRECTION OF FLOOR MEMBER PER SCHEDULE. REFER TO HATCHED WALLS ON PLANS FOR INTERMEDIATE BR'G
- ◇ DIRECTION OF DECK OR ROOF RAFTERS MEMBER PER SCHEDULE. REFER TO HATCHED WALLS ON PLANS FOR INTERMEDIATE BR'G
- ◇ SHEAR PANEL LENGTH AND NUMBER. REFER TO GN FOR PANEL TYPE, MIN. 2-2x4 @ EA. END.
- DETAIL NUMBER DETAIL SHEET NUMBER
- BEAM NUMBER, REFER TO E.O.R. CALCULATIONS
- KEY NOTE NUMBER
- CALIFORNIA FRAMING
- FLOOR TO FLOOR HOLDOWN PER SCHEDULE BELOW:
- FLOOR TO FLOOR HOLDOWN PER SCHEDULE BELOW:
- FLOOR TO FLOOR HOLDOWN PER SCHEDULE BELOW:
- FLOOR TO FLOOR HOLDOWN PER SCHEDULE BELOW:

KEY NOTES

- ALIGN STUD(S) / POST(S) WITH UPPER FLOOR STUD(S) / POST(S) AND PROVIDE SOLID BLOCKING BETWEEN FLOOR (PROVIDE E.N. WHEN POST IS LOCATED WITHIN S.W.)
- PROVIDE SOLID BLOCKING
- CONTINUOUS JOIST W/ E.N.
- DRAG TRUSS W/E.N. TRUSS TO TRANSFER 1650# FORCE MIN. (U.N.O.)
- SHEAR TRUSS W/E.N. TRUSS TO TRANSFER 200 PLF MIN. (U.N.O.)
- LINE OF 2x PLAT BLOCKING W/ EDGE NAIL, & CONTINUOUS CS16 STRAP OVER U.N.O. SEE PLAN FOR NUMBER OF BAYS.
- CONTINUOUS FULL HT. BLKG. W/E.N. SEE PLANS FOR NUMBER OF BAYS (U.N.O.)
- TRUSS HANGER BY TRUSS SUPPLIER
- (1) SIMPSON TS22 FLUSH BEAM TO DROP BEAM (U.N.O.)
- CONTINUOUS TIMBERSTRAND OR SPLICE PER PLAN.
- BLOCKED ROOF DIAPHRAGM W/ 8d's @ 4" O.C. B.N., 6" O.C. E.N. & 12" O.C. FIELD.
- BLOCKED FLOOR DIAPHRAGM W/ 10d's @ 2 1/2" O.C. B.N., 4" O.C. E.N. & 12" O.C. FIELD.
- CONTINUOUS LINE OF BLOCKING W/ EDGE NAIL
- UNDER SHEAR WALL ABOVE W/ (1) CS16, U.N.O.
- DRAG STRUT W/E.N. SEE PLANS/DETAILS FOR LENGTH, SUPPORT END W/ BLK'G
- TRUSS DESIGNER TO CONSIDER ADDITIONAL #PSF DEAD LOAD FOR FUTURE SOLAR PANELS IN DESIGN.
- TRUSS DESIGNER TO CONSIDER WEIGHT OF WALL ABOVE. IF STUCCO, THEN CONSIDER 17 PSF. IF STONE VENEER, THEN CONSIDER 32 PSF.
- PROVIDE SIMPSON STRAP @ SPLICE
- CUSTOM HEIGHT HARDY FRAME TO MATCH FIELD CONDITION, CONTRACTOR TO VERIFY HEIGHT PRIOR TO ORDER (TOP OF HARDY FRAME SHOULD BE BOTTOM OF BEAM SEE DETAIL 31/503)
- PROVIDE 3 1/4" X F.H. LVL W/E.N
- PROVIDE 3 1/2" X F.H. LVL W/E.N
- USE 10 d's NAILS FOR B.N. & E.N. & F.N. WHERE 1/2" THICK FILLER APPLIED TO T.O.B.
- USE FOAM ROOF ONLY (MAX 16 PSF TOTAL DEAD LOAD)

FRAMING SCHEDULE

- 20" TJI 360 ROOF JOISTS @ 24" O.C.
- 2 x 8 ROOF JOISTS / RAFTERS @ 16" O.C.

FRAMING NOTES

- REFER TO GN & GD SHEETS FOR MORE INFORMATION.
- REFER TO DETAIL 3/GD FOR TYPICAL CONNECTION AT ALL INTERIOR NON-BEARING WALLS AT ROOF LEVEL.
- SHEAR WALLS CANNOT BE USED AS PLUMBING WALLS, UNLESS APPROVED BY E.O.R. IN WRITING.
- AT DOUBLE SIDED SHEAR WALLS, POST W/E.N. PER PLAN TO RECEIVE E.N. FROM BOTH SIDES.
- WHEN MULTIPLE STUDS ARE USED INSTEAD OF A SINGLE POST, PLYWOOD SHEAR WALL TO BE NAILED TO ALL STUDS RECEIVING HOLDOWNS.
- APPLY SHEAR PRIOR TO FRAMING OF PERPENDICULAR WALLS. DO NOT BREAK SHEAR AT PERPENDICULAR WALL LOCATIONS UNLESS SPECIFICALLY DETAILED ON PLANS.
- ALL VERTICAL PIPES THROUGH PLATES AND/OR SOLID RIM BEAMS MUST BE DRILLED CLEAN CUT W/ 1/16" TOLERANCE. DO NOT NOTCH OR CUT PLATES.
- ALL BEAMS SHOWN ARE DROP (U.N.O.) ON PLANS.
- USE SIMPSON "LUS" HANGERS FOR CONNECTION OF I-JOISTS TO OTHER FRAMING MEMBERS (U.N.O.) AND "LUS" HANGERS FOR CONNECTION OF SOLID JOISTS.
- ALL WOOD I-JOISTS SHALL BE IN COMPLIANCE WITH THE PROVISIONS OF APA PRI-400, EWS-2725B (PERFORMANCE RATED I-JOIST STANDARD) OR ASTM D5055, QUALIFIED PRI-400, MANUFACTURED. SUBMIT SHOP DRAWING TO E.O.R. FOR REVIEW AND APPROVAL.
- A 4x6 HEADER SHOULD BE USED AT ALL OPENINGS IN EXTERIOR & INTERIOR BEARING WALLS U.N.O. ON PLANS. ALL 4x6 TO 8x12 SIZES CAN BE SUBSTITUTED WITH 2-2x 12 TO MATCH THE DEPTH AND THE 2-2x SHALL BE PLACED ON END WITH 1/2" PLYWOOD SHM BETWEEN. PROVIDE 16d NAILS @ 16" O.C., STAGG., BOTH SIDES.
- USE 2x TRIMMER FOR HEADERS LESS THAN 6'-0" AND 2-2x FOR 6'-0" TO 10'-0" LONG SPAN IN BEARING WALLS, U.N.O. ON THE PLAN. REQUIRED TRIMMER MUST BE APPLIED @ EACH END OF HEADER. SEE PLANS FOR HEADERS LARGER THAN 10'-0" LONG.
- INTERIOR NON-BEARING WALLS MAY BE FRAMED WITH 2x STUDS AT 24" O.C. MAX.
- TOP PLATES AT ALL ROOF FRAMING LEVELS SHOULD BE SPICED PER 98/SD2 U.N.O. ON PLANS.
- CONTINUOUS 1"x1" LVL RIM JOISTS SHOULD BE USED AT ALL FLOOR FRAMING EDGES WHERE POSSIBLE. ALL RIM BREAKS SHOULD BE SPICED WITH A SINGLE CS16 X36" STRAP, PER 44/SD2 U.N.O. ON PLANS.
- ALL SIMPSON LEG/MEG/EG HANGERS SHALL BE ORDERED W/TOP FLANGE.

NOTE: CONTRACTOR IS RESPONSIBLE FOR VERIFYING HARDY FRAMES MATCH TOP PLATE HEIGHT & NOTIFY ENGINEER OF RECORD IF DIFFERENT THAN PLANS.

SEE SHEETS HFX-1 & HFX-2/HFX3 FOR MANUFACTURER INSTALLATION REQUIREMENTS

I-JOIST CONVERSION TABLE

MANUFACTURER	I LEVEL BY WETTERHAUSER		ROSEBURG		ROSE CASCADE	
	CC-15 REPORT	ESR-1153	ESR-1251	ESR-1136	ESR-1251	ESR-1136
11 7/8"	TJ 210	RFR-400	BCI 6000-1.2			
	TJ 360	RFR-70	BCI 600-2.0			
14" TO 18"	TJ 210	RFR-400	BCI 6000-1.8			
	TJ 360	RFR-70	BCI 600-2.0			

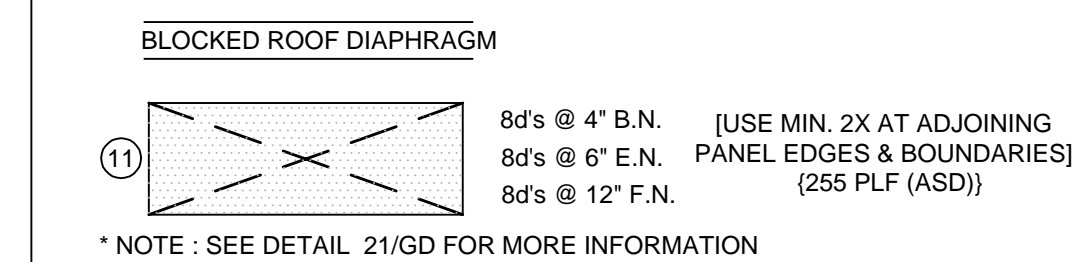

* NOTE: SEE DETAIL 21/GD FOR MORE INFORMATION

RA STRUCTURAL ENGINEERING, INC.
 REZA ASGHARPOUR, P.E.
 77570 SPRINGFIELD LANE,
 SUITE D
 PALM DESERT, CA 92211
 PHONE: 760-360-9998
 FAX: 760-360-9903
 EMAIL: REZA@RASTRUCTURAL.COM
 PROJECT NAME:

(3BD)

- A.B. ANCHOR BOLT ABOVE
- ABV. REIN. BAR
- BD. BOARD BLOCKING
- BL.W. BELOW
- BM. BEAM
- B.N. BOUNDARY NAIL
- B.O.B. BOTTOM OF BEAM
- B.O.J. BOTTOM OF JOIST
- B.O.T. BOTTOM OF TRUSS
- E.W. EACH WAY
- CF. CONTINUOUS FOOTING
- CJ. CEILING JOIST
- COL. COLUMN
- CONC. CONCRETE
- CONT. CONTINUOUS
- C.P.E. CONT. PANEL
- D. DEPTH
- DBL. DOUBLE
- D.F. DOUGLAS FIR
- DIA. DIAMETER
- DITTO DITTO
- DO. EXISTING
- E.J. EACH WAY
- E.N. EXPANSION JOINT
- EQ. EQUAL FLOOR BEAM
- F.G. FINISH GRADE
- F.J. FLOOR JOIST
- FL. FLUSH
- FMG. FRAMING
- F.N. FIELD NAIL
- F.O.C. FACE OF CONCRETE
- F.O.M. FACE OF MASONRY
- F.O.S. FACE OF STUDS
- F.P. FULL PENETRATION
- FTG. FOOTING
- GA. GALVANIZED
- GALV. GALVANIZED
- GLB. GLUE-LAMINATED BEAM
- GR.BM. GRADE BEAM
- GW.B. GYPSUM WALLBOARD
- H. HIGH
- HDR. HEADER
- HFX. HARDY FRAME
- HGT. HEIGHT
- HORIZ. HORIZONTAL
- K.P. KING POST
- LE. LENGTH
- LT.WT. LIGHT WEIGHT
- L.V.L. LAMINATED VENEER LUMBER
- M.S. MASONRY
- M.B. MACHINE BOLT
- MLB. MICRO-LAM BEAM
- (N) NEW
- N.G. NATURAL GRADE
- O/C. ON CENTER
- P.J. POUR JOINT
- PL.B. PARALLAM BEAM
- PL.WD. PLYWOOD
- P.T. PRESSURE TREATED
- R.B. ROOF BEAM
- REINF. REINFORCING
- REQD. REQUIRED
- RF. ROOF
- RR. ROOF RAFTER
- T.O.B. TOP OF BEAM
- V.I.F. VERIFY IN FIELD

DESIGNER:
Jonathan Pelezare

DEVELOPER:
N/A

ADDRESS:

REVISIONS

NO.	DATE	DESCRIPTION

SHEET NAME:
HIGH ROOF FRAMING PLAN

PROJECT NUMBER:
220653

DESIGNED BY: CHECKED BY:
R.A./H.K. R.A.

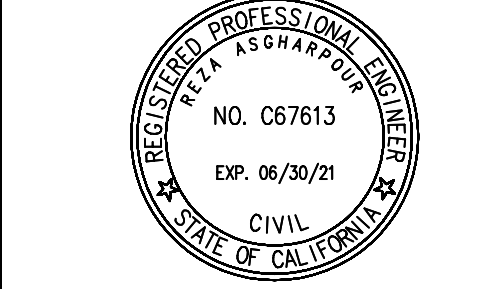

PLOT DATE:
08/23/2022

SHEET NUMBER:
S-3

- A.B. ANCHOR BOLT ABOVE
- ABV. REIN. BAR
- BD. BOARD BLOCKING BELOW
- B.W. BEAM
- BM. BOUNDARY NAIL BOTTOM OF NAIL BOTTOM OF JOIST
- B.O.B. BOTTOM OF JOIST
- B.O.T. BOTTOM OF JOIST
- E.W. EACH WAY
- CF. CONTINUOUS FOOTING
- CJ. CEILING JOIST
- COL. COLUMN
- CONC. CONCRETE
- CONT. CONTINUOUS
- C.P.E. CONT. PANEL
- D. DEPTH
- DBL. DOUBLE
- D.F. DOUGLAS FIR
- DIA. DIAMETER
- DITTO DITTO
- EXIST. EXISTING
- E.W. EACH WAY
- E.J. EXPANSION JOINT
- E.N. EDGE NAIL
- EQ. EQUAL FLOOR BEAM
- F.G. FINISH GRADE
- F.J. FLOOR JOIST
- FL. FLUSH
- FLM. FRAMING
- F.N. FIELD NAIL
- F.O.C. FACE OF CONCRETE
- F.O.M. FACE OF MASONRY
- F.O.S. FACE OF STUDS
- F.P. FULL PENETRATION
- FTG. FOOTING
- G. GAUGE
- GA. GALVANIZED
- GLB. GLUE-LAMINATED BEAM
- GR.BM. GRADE BEAM
- GWB. GYPSUM WALLBOARD
- H. HIGH
- HDR. HEADER
- HFX. HARDY FRAME
- HGT. HEIGHT
- HORIZ. HORIZONTAL
- K.P. KING POST
- LENGTH LENGTH
- LT.WT. LIGHT WEIGHT
- L.V.L. LAMINATED VENEER LUMBER
- MAS. MASONRY
- M.B. MACHINE BOLT
- MLB. MICRO-LAM BEAM
- (N) NEW
- N.G. NATURAL GRADE
- O/C ON CENTER
- P.J. POUR JOINT
- P.LB. PARALLAM BEAM
- PLWD. PLYWOOD
- P.T. PRESSURE TREATED
- R.B. ROOF BEAM
- REIN. REINFORCING
- REQD. REQUIRED
- RF. ROOF
- RR. ROOF RAFTER
- T.O.B. TOP OF BEAM
- V.I.F. VERIFY IN FIELD

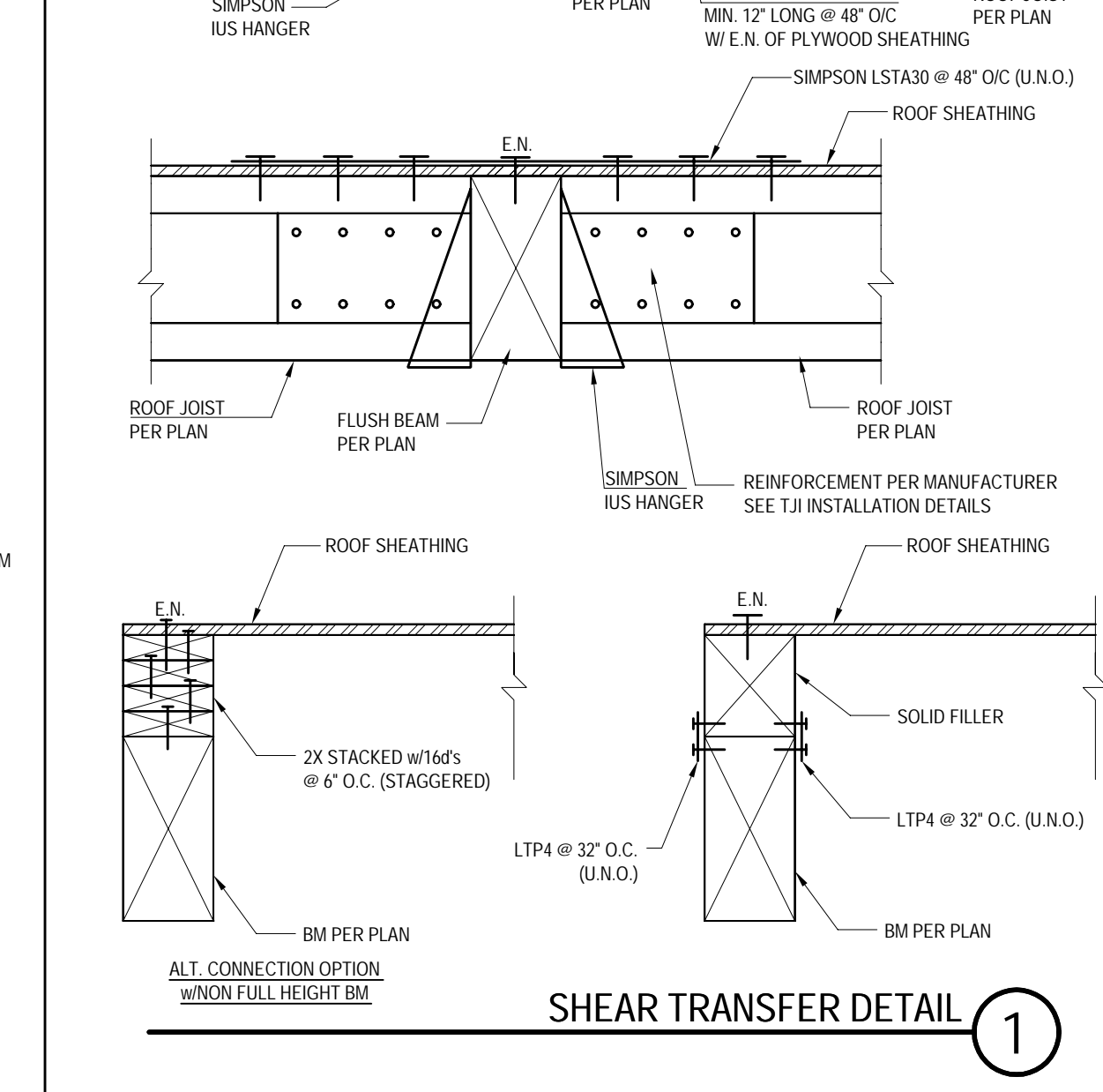
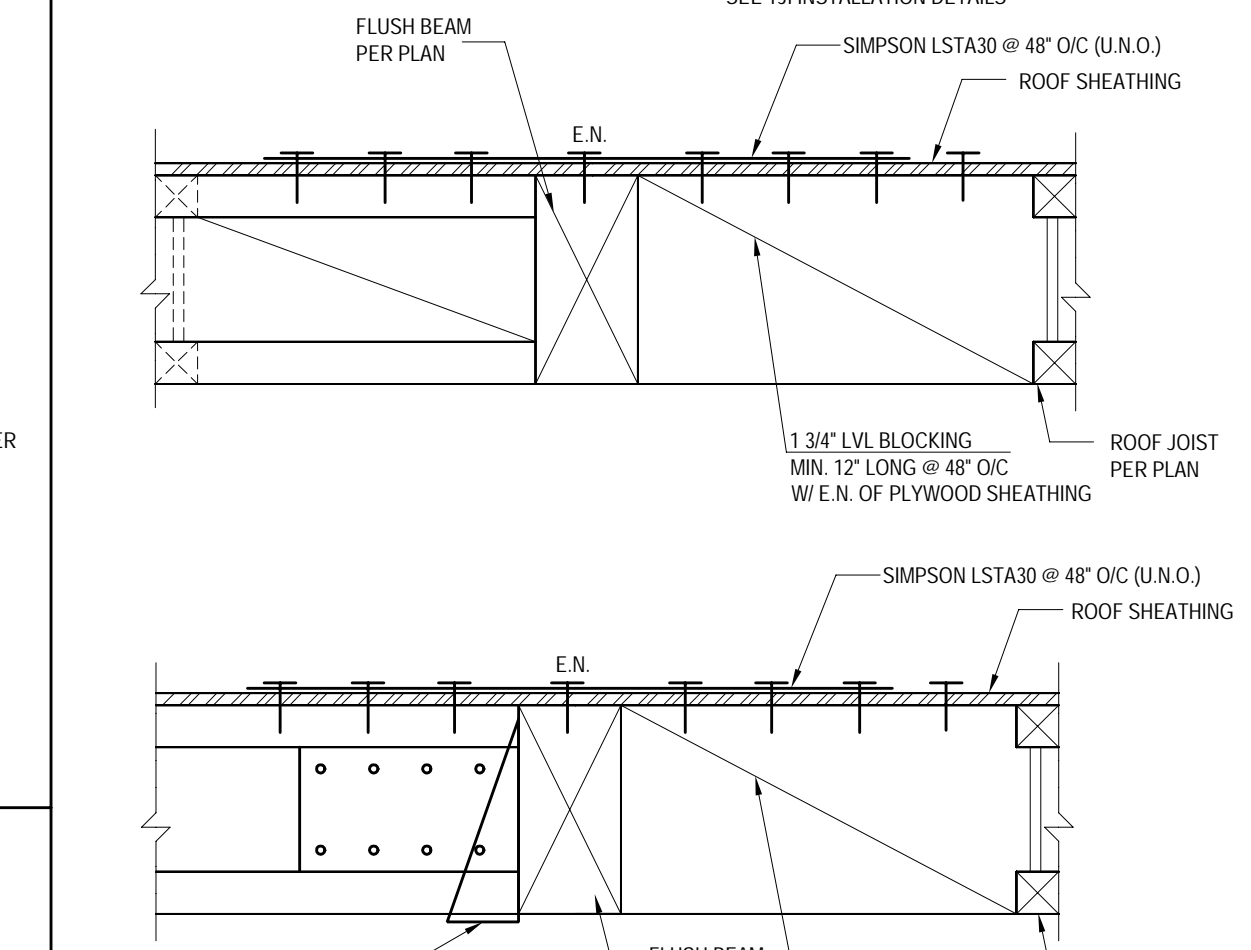
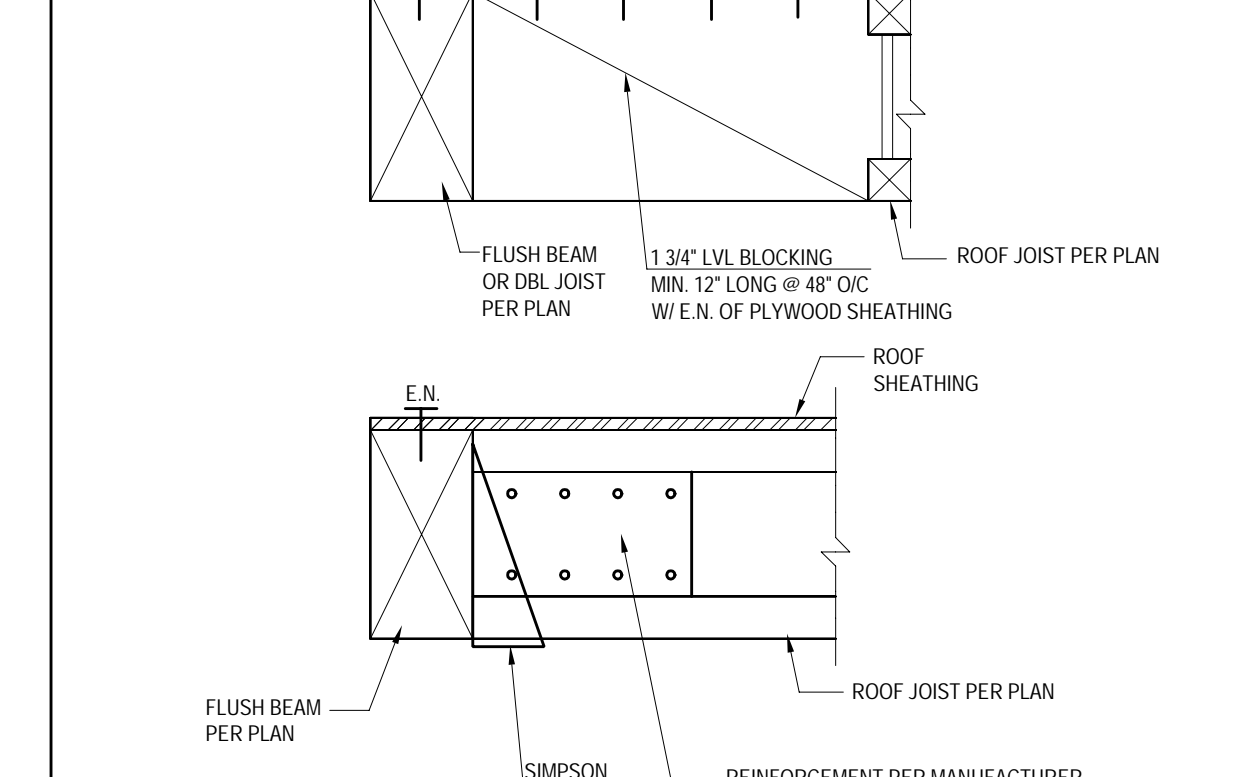
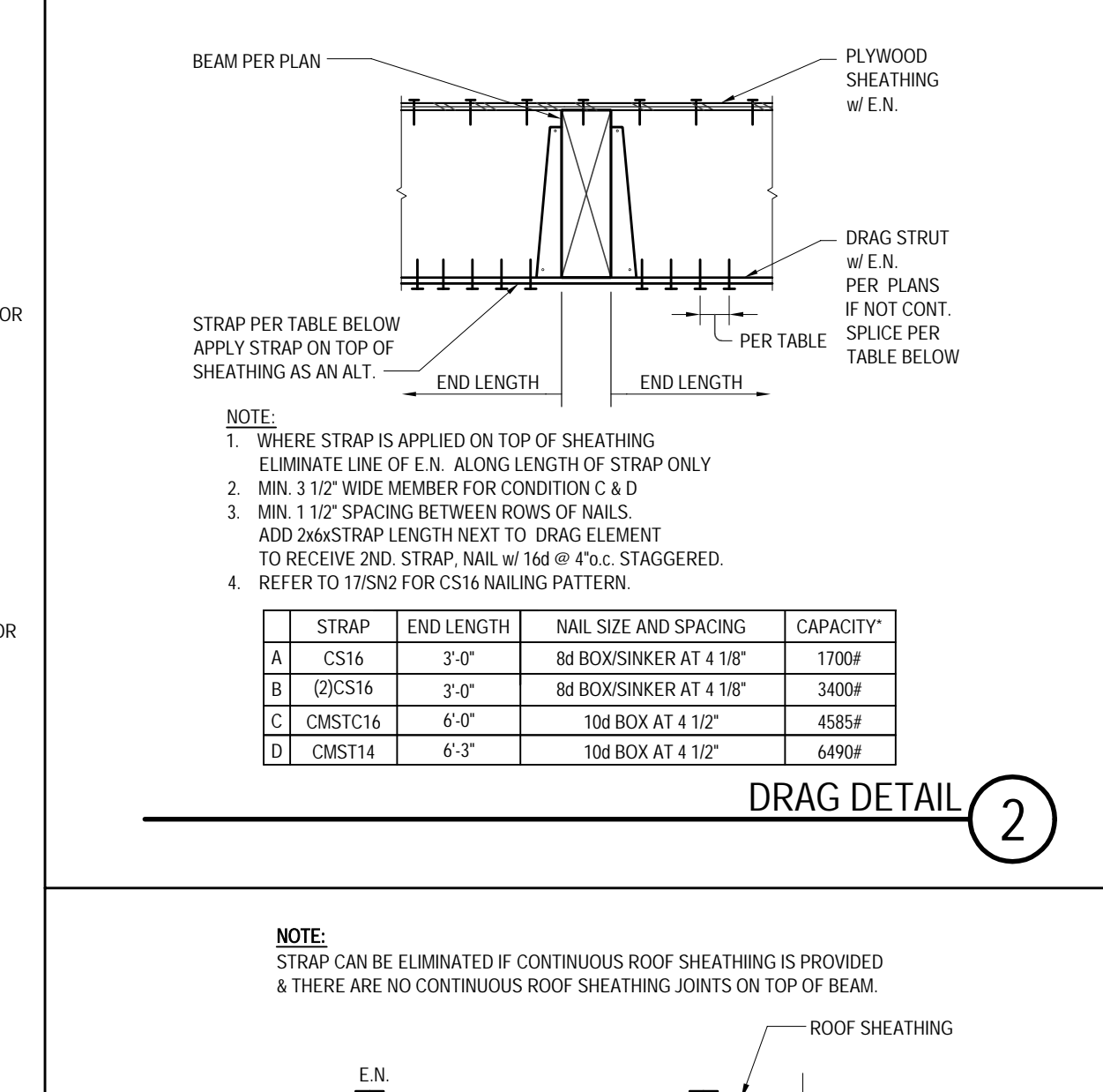
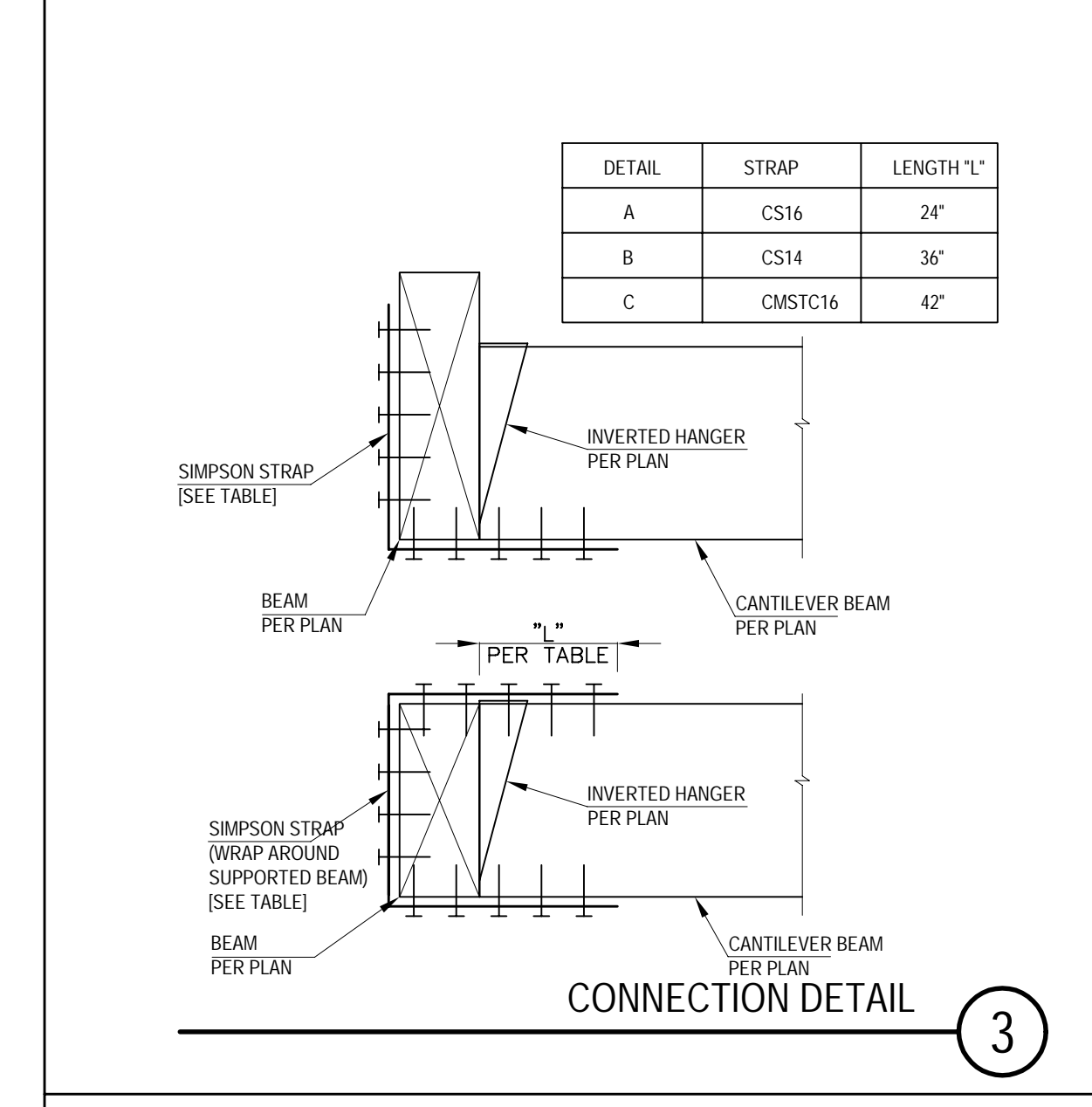
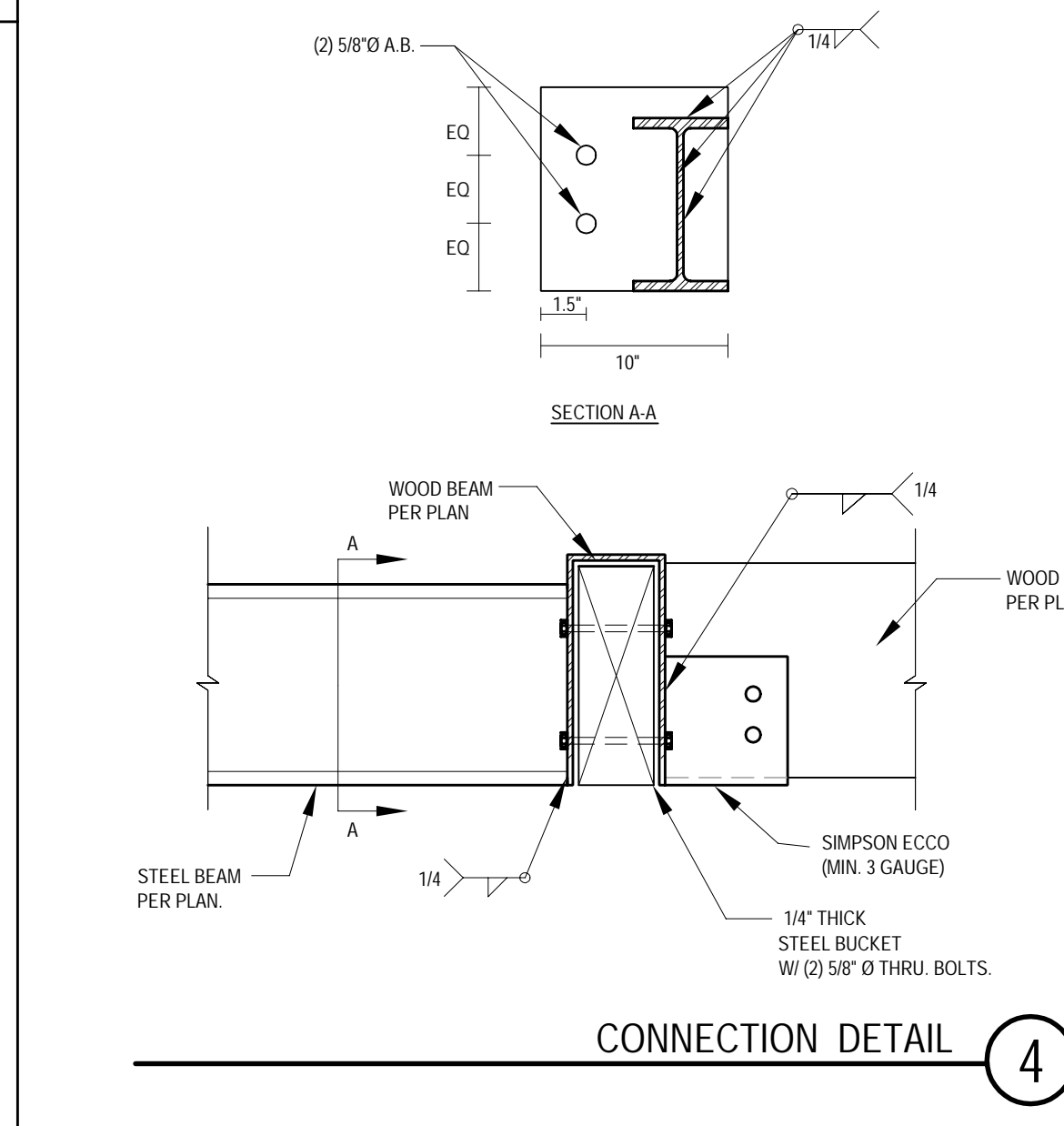
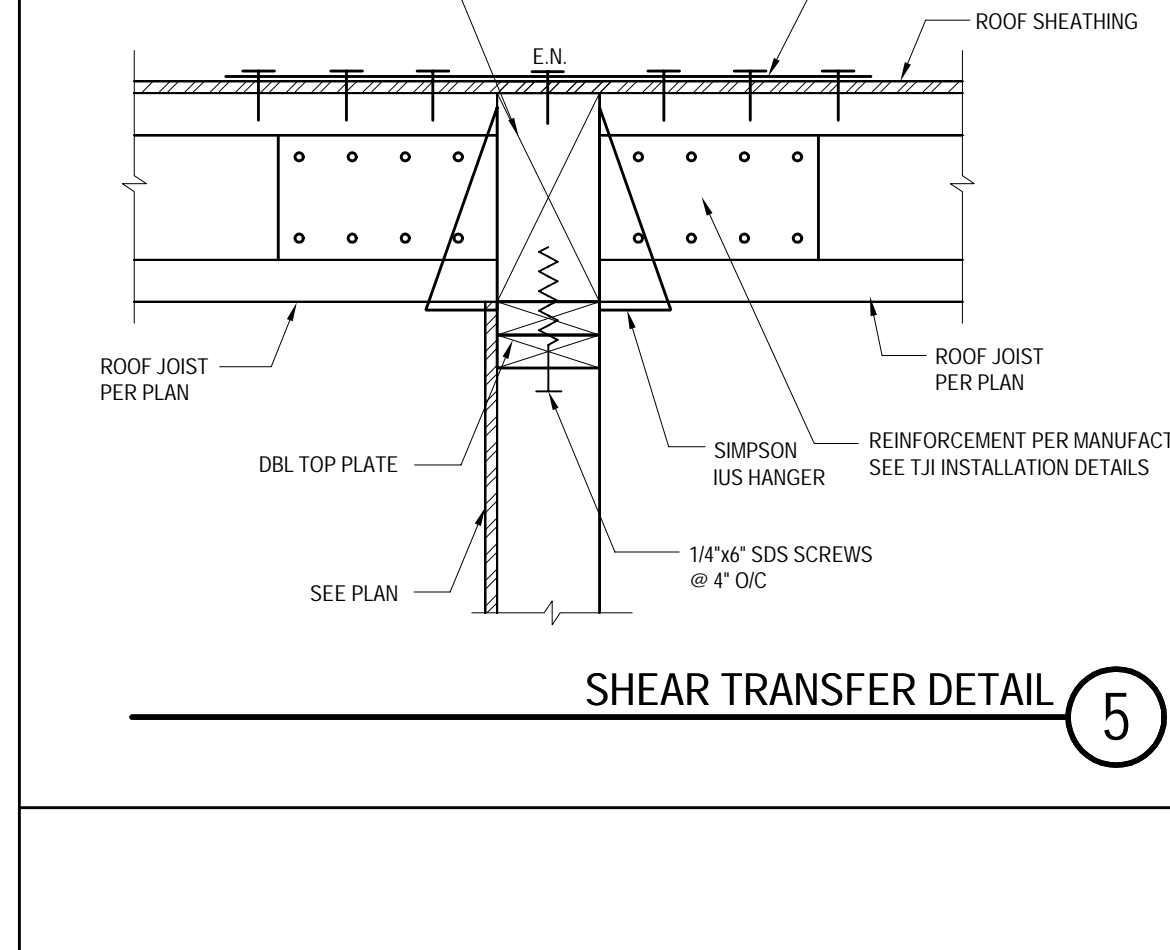
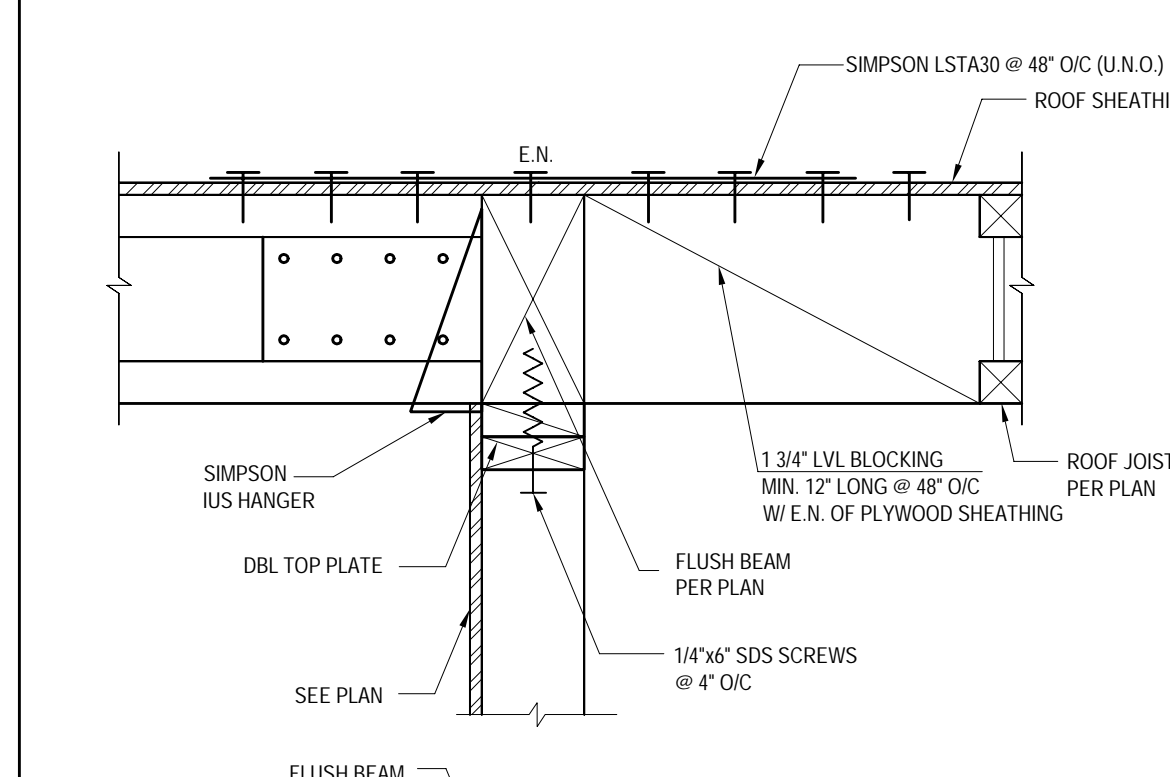
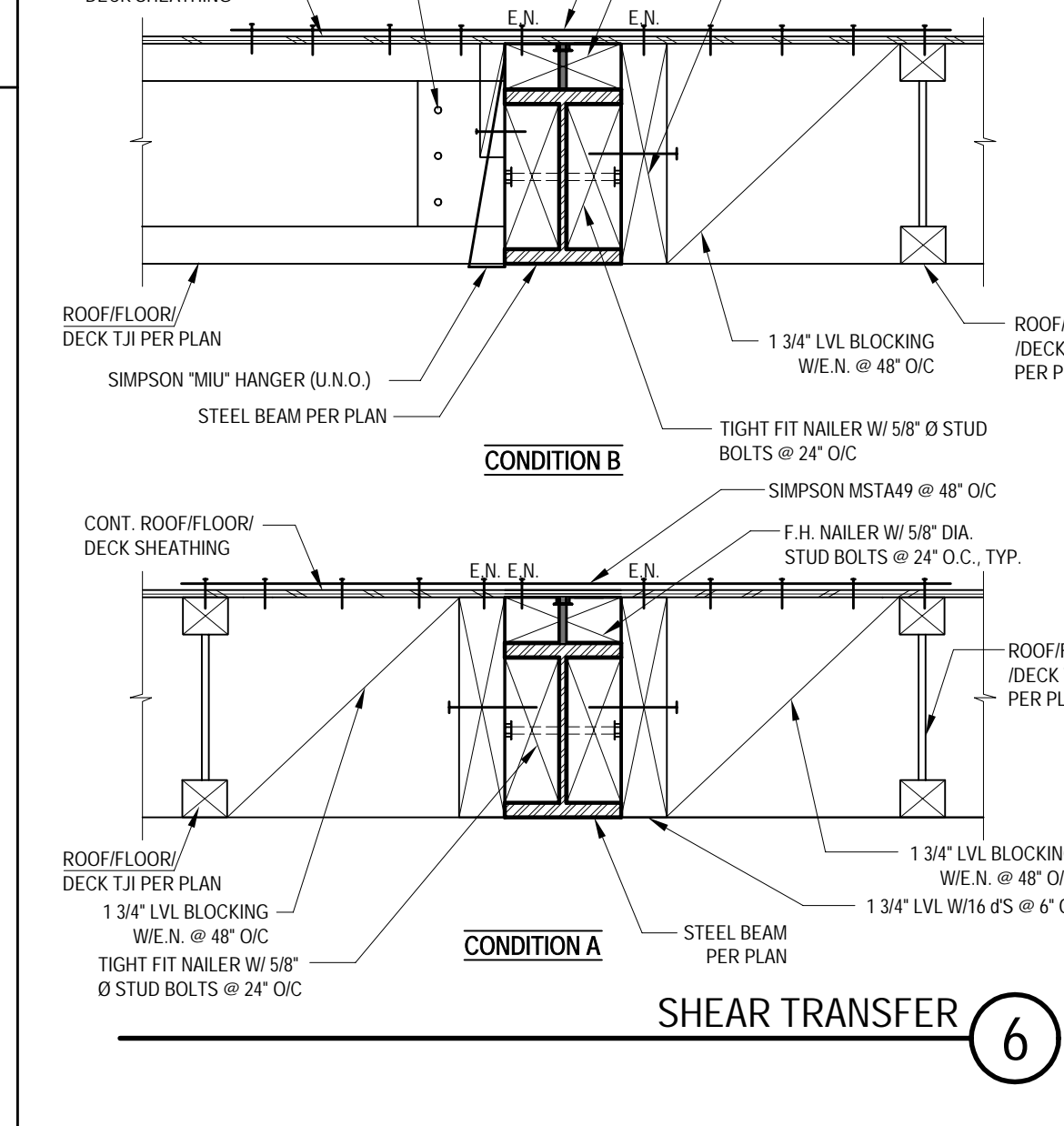
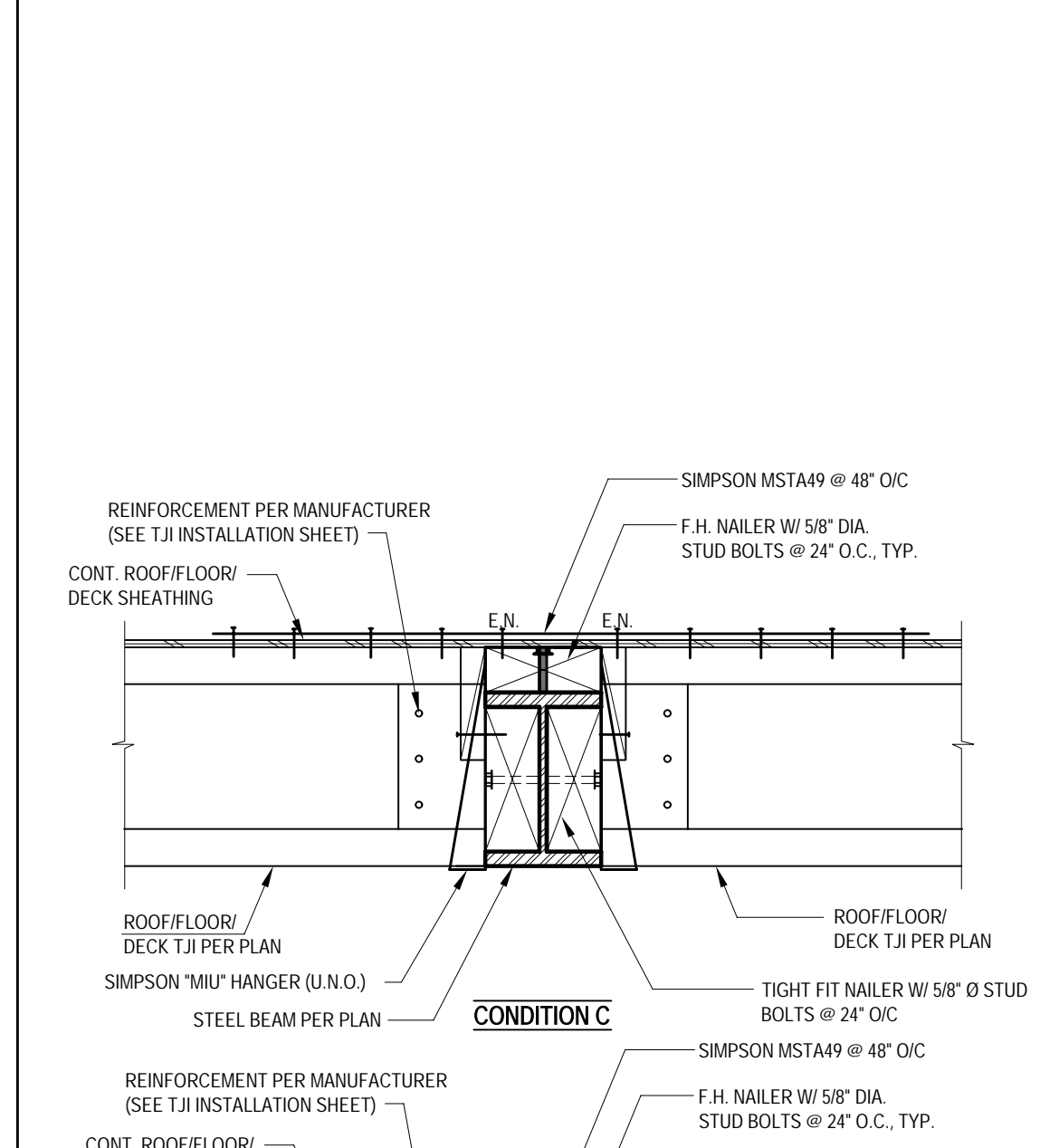
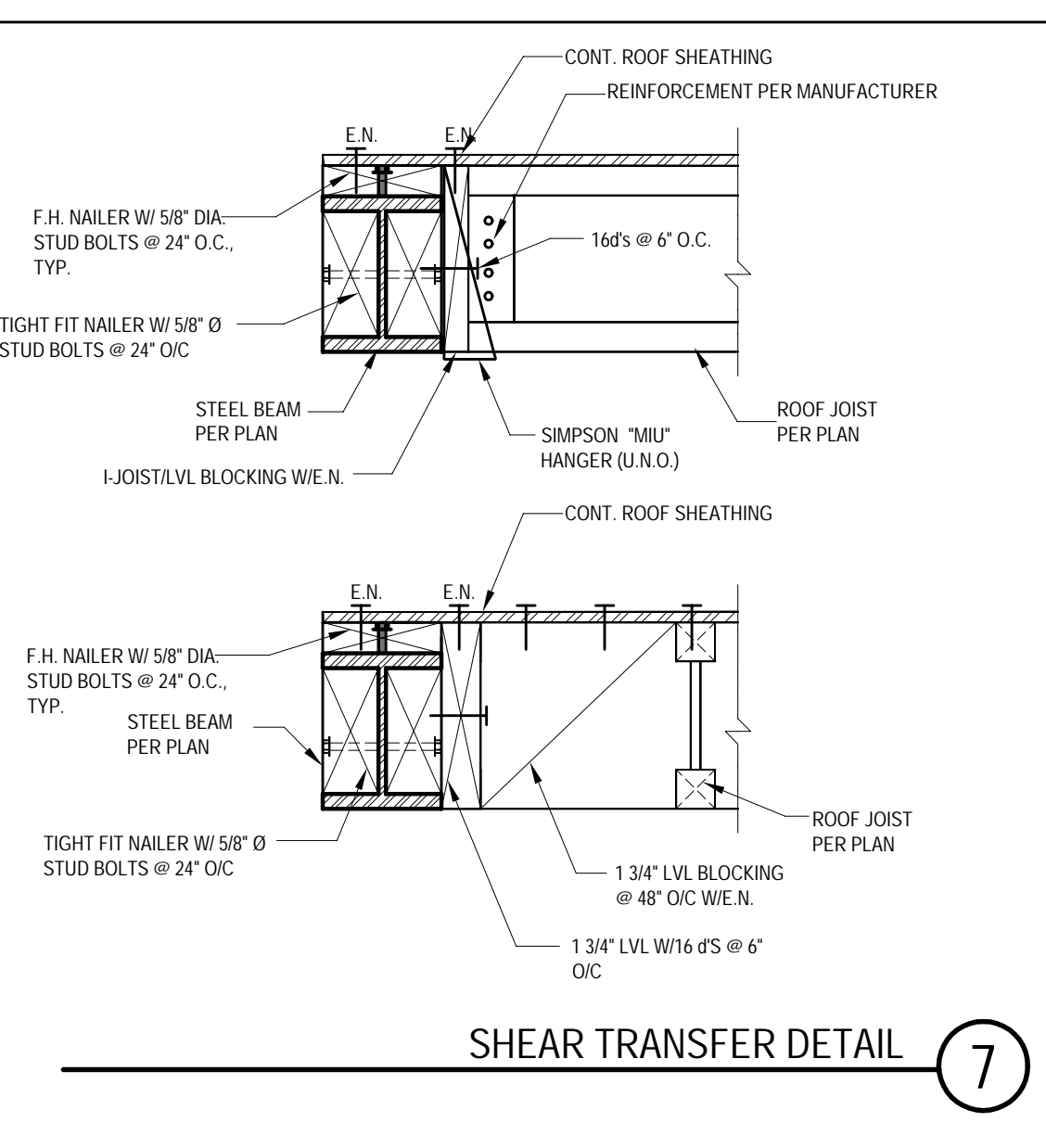
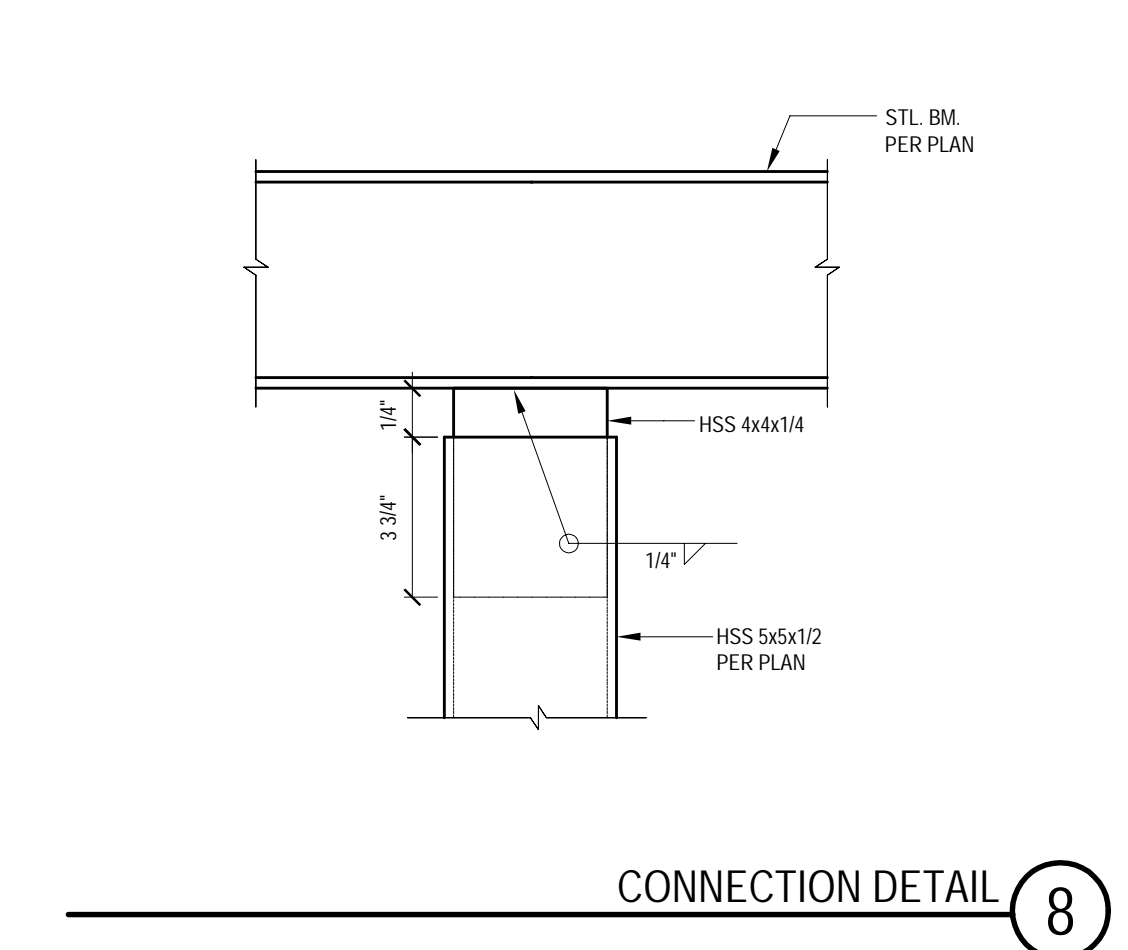
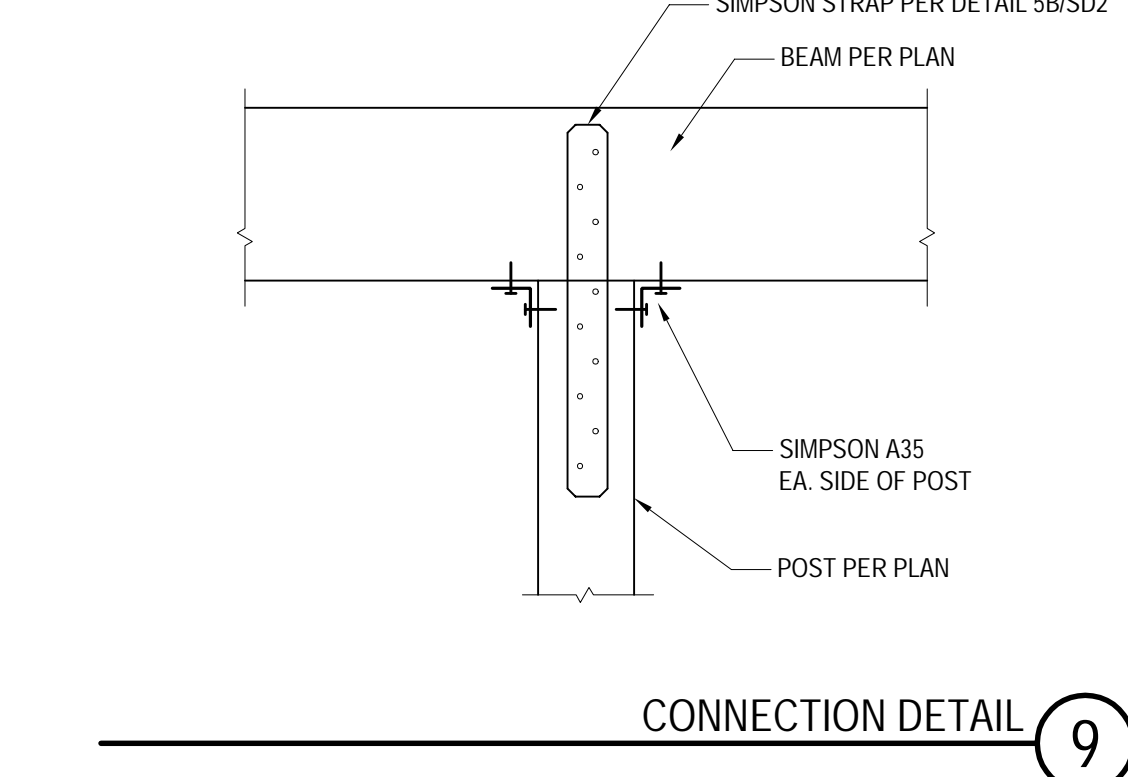
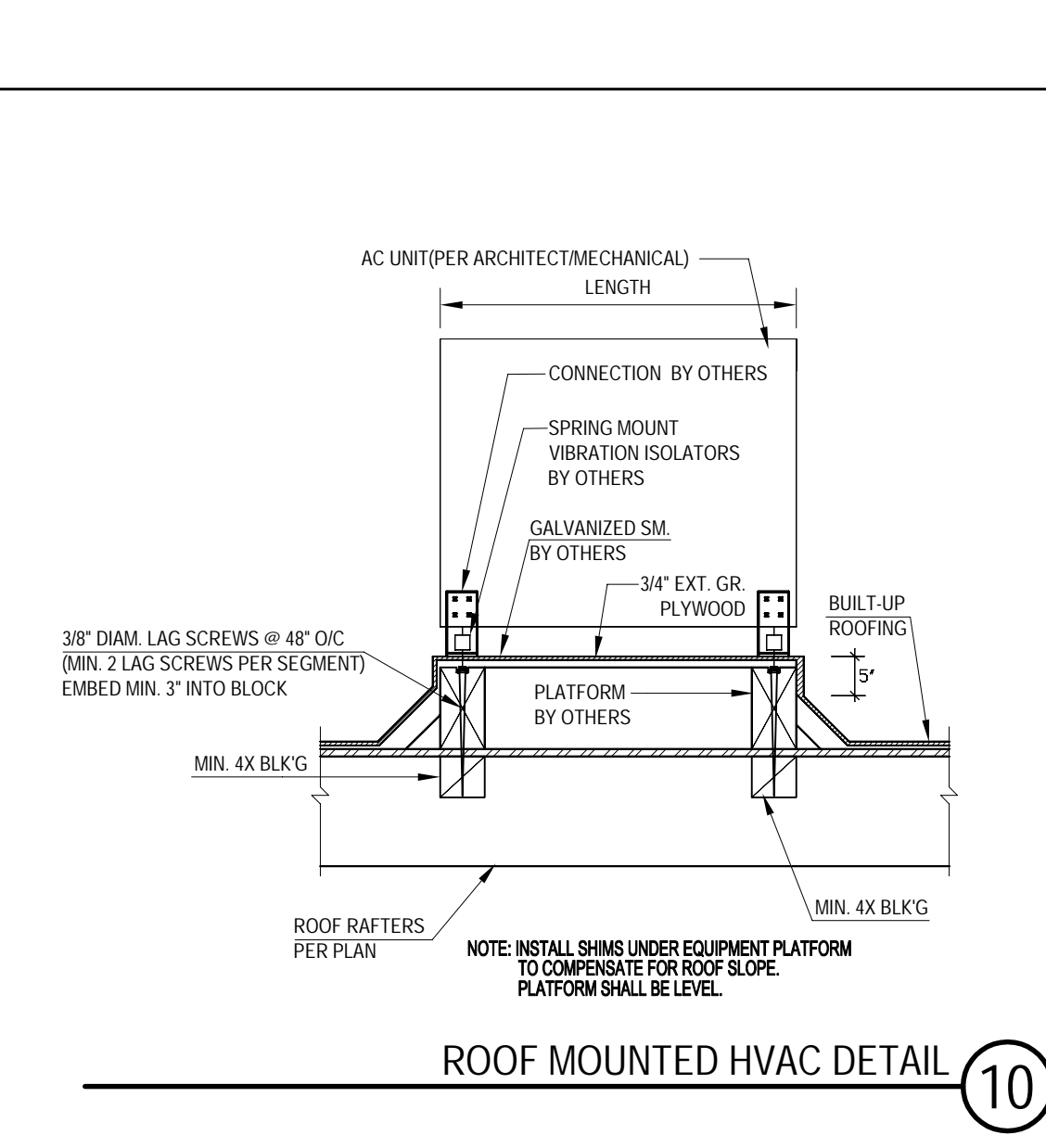
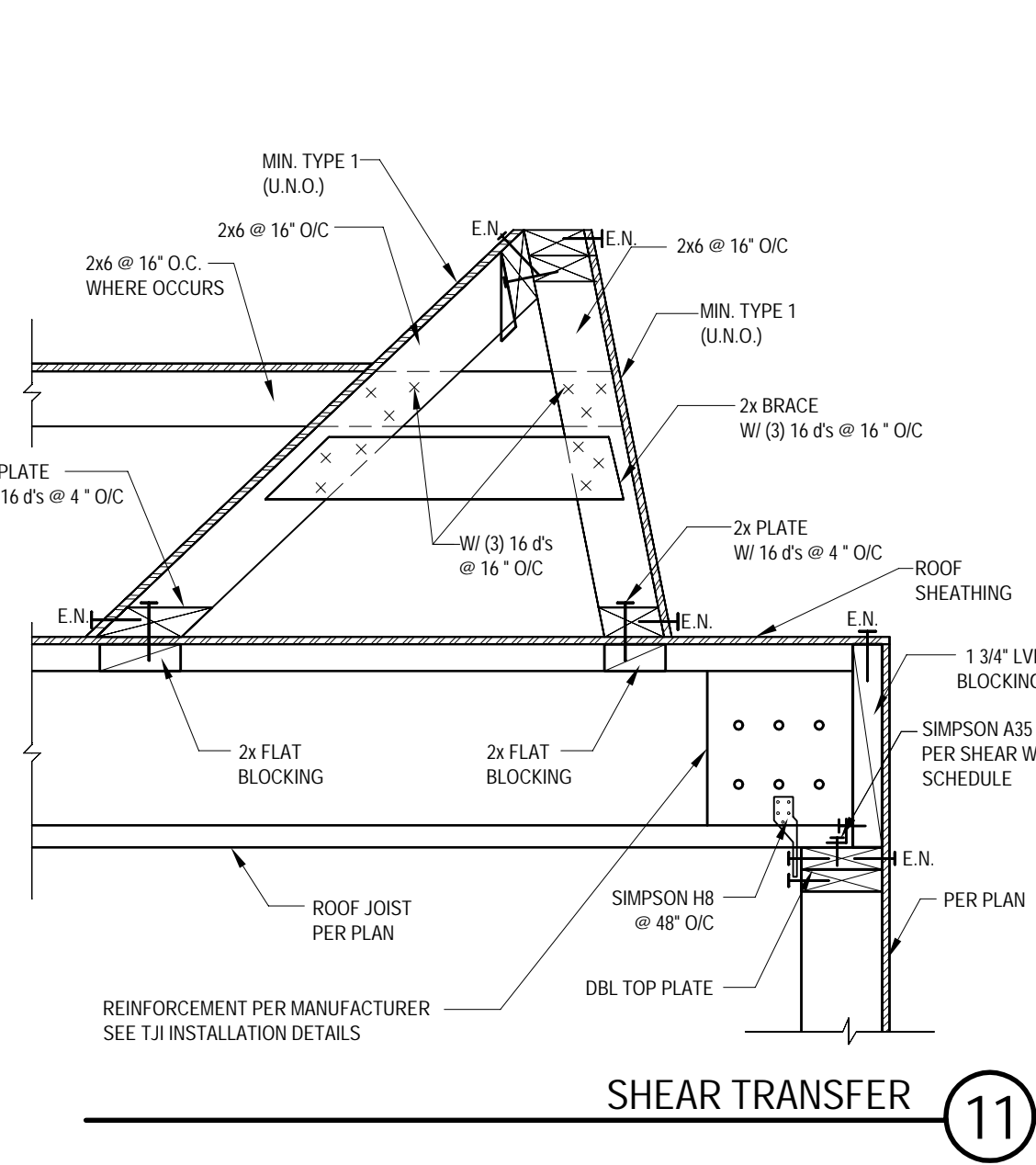

DRAG DETAIL 12

STRAP	END LENGTH	NAIL SIZE & SPACING	CAPACITY*
A	CS16	3'-0"	84 @ 2 1/16" 1600F
B	CS16	2'-0"	84 @ 2 1/16" 3200F
C	CMSTC16	4'-4"	16 @ 3" 4300F
D	CS16	2'-0"	84 @ 2 1/16" 1000F
E	CS14	3'-0"	84 @ 2 1/16" 2450F
F	CMST12	8'-0"	16 @ 3" 9215F

